

FEATURES

- Single chip DS1 rate transceiver
- Supports common framing standards
 - 12 frames/superframe "193S"
 - 24 frames/superframe "193E"
- Three zero suppression modes
 - B7 stuffing
 - B8ZS
 - Transparent
- Simple serial interface used for configuration, control and status monitoring in "processor" mode
- "Hardware" mode requires no host processor; intended for stand-alone applications
- Selectable 0, 2, 4, 16 state robbed bit signaling modes
- Allows mix of "clear" and "non-clear" DS0 channels on same DS1 link
- Alarm generation and detection
- Receive error detection and counting for transmission performance monitoring
- 5V supply, low-power CMOS technology
- Surface mount package available, designated DS2180AQ
- Industrial temperature range of -40°C to +85°C available, designated DS2180AN or DS2180AQN
- Compatible to DS2186 Transmit Line Interface, DS2187 Receive Line Interface, DS2188 Jitter Attenuator, DS2175 T1/CEPT Elastic Store, DS2290 T1 Isolation Stik, and DS2291 T1 Long Loop Stik

DESCRIPTION

The DS2180A is a monolithic CMOS device designed to implement primary rate (1.544 MHz) T-carrier transmission systems. The 193S framing mode is intended to support existing Ft/Fs applications (12 frames/superframe). The 193E framing mode supports the extended superframe format (24 frames/superframe). Clear channel capability is provided by selection of appropriate zero suppression and signaling modes.

PIN ASSIGNMENT

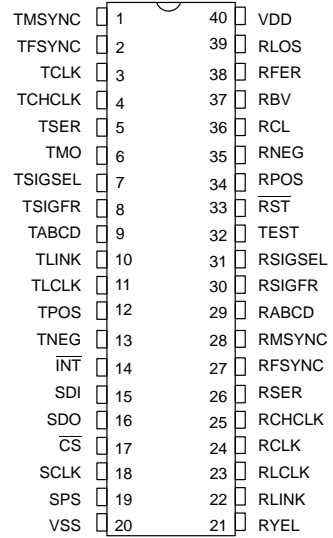

40-Pin DIP (600 MIL)

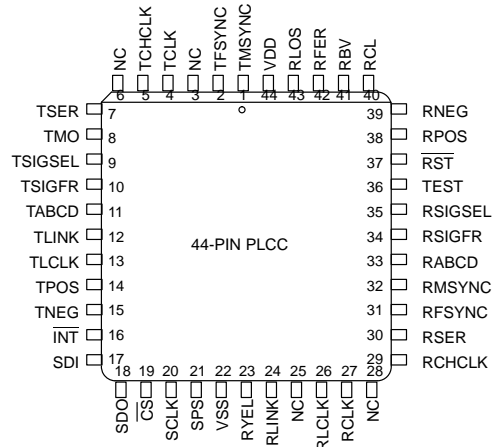

44-PIN PLCC

Several functional blocks exist in the transceiver. The transmit framer/formatter generates appropriate framing bits, inserts robbed bit signaling, supervises zero suppression, generates alarms, and provides output clocks useful for data conditioning and decoding.

The receive synchronizer establishes frame and multi-frame boundaries by identifying frame signaling bits, extracts signaling data, reports alarms and transmission errors, and provides output clocks useful for data conditioning and decoding.

The control block is shared between transmit and receive sides. This block determines the frame, zero sup-

pression, alarm and signaling formats. User access to the control block is by one of two modes.

In the processor mode, pins 14 through 18 are a micro-processor/microcontroller-compatible serial port which can be used for device configuration, control and status monitoring.

In the hardware mode, no offboard processor is required. Pins 14 through 18 are reconfigured into "hard-wired" select pins. Features such as selection "clear" DS0 channels, insertion of idle code and alteration of sync algorithm are unavailable in the hardware mode.

DS2180A BLOCK DIAGRAM Figure 1

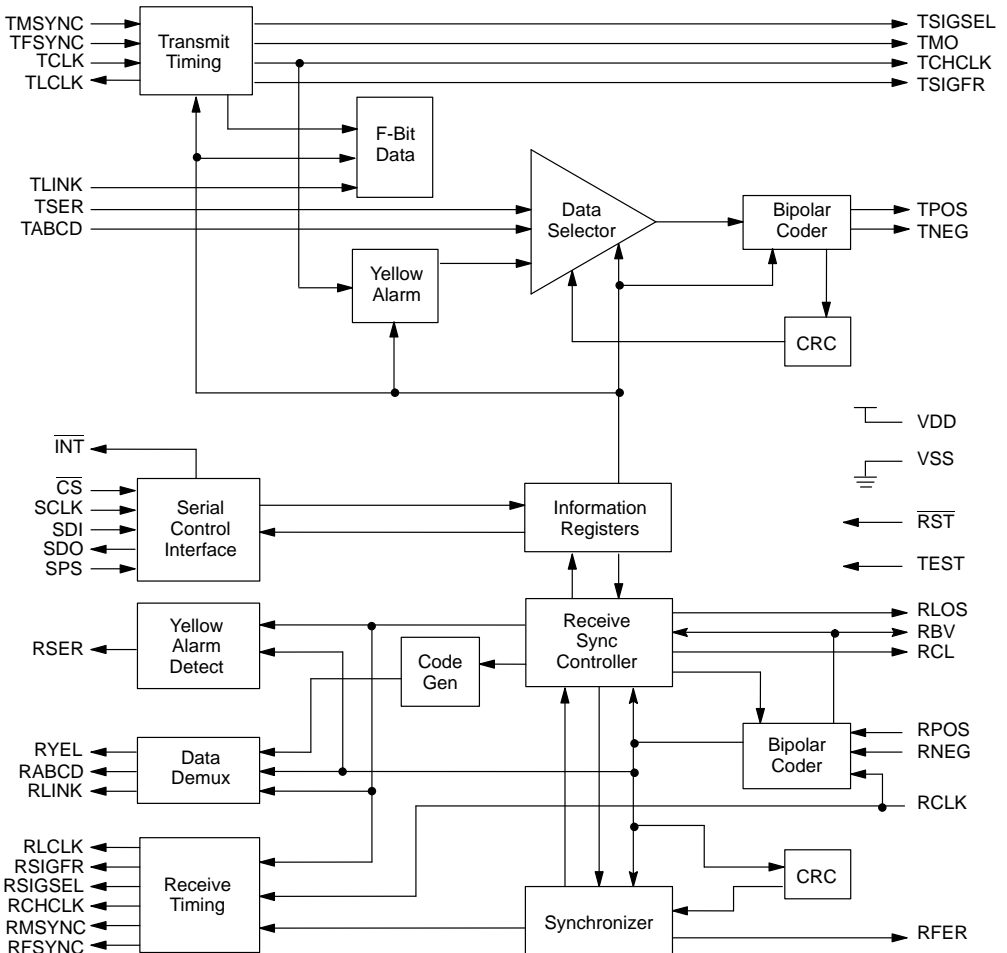

TRANSMIT PIN DESCRIPTION (40–PIN DIP ONLY) Table 1

PIN	SYMBOL	TYPE	DESCRIPTION
1	TMSYNC	I	Transmit Multiframe Sync. May be pulsed high at multiframe boundaries to reinforce multiframe alignment or tied low, which allows internal multiframe counter to free run.
2	TFSYNC	I	Transmit Frame Sync. Rising edge identifies frame boundary; may be pulsed every frame to reinforce internal frame counter or tied low (allowing TMSYNC to establish frame and multiframe alignment).
3	TCLK	I	Transmit Clock. 1.544 MHz primary clock.
4	TCHCLK	O	Transmit Channel Clock. 192 KHz clock which identifies time slot (channel) boundaries. Useful for parallel-to-serial conversion of channel data.
5	TSER	I	Transmit Serial Data. NRZ data input, sample on falling edge of TCLK.
6	TMO	O	Transmit Multiframe Out. Output of internal multiframe counter indicates multiframe boundaries. 50% duty cycle.
7	TSIGSEL	O	Transmit Signaling Select. .667 KHz clock which identifies signaling frame A and C in 193E framing. 1.33 KHz clock in 193S.
8	TSIGFR	O	Transmit Signaling Frame. High during signaling frames, low otherwise.
9	TABCD	I	Transmit ABCD Signaling. When enabled via TCR.4, sampled during channel LSB time in signaling frames on falling edge of TCLK.
10	TLINK	I	Transmit Link Data. Sampled during the F-bit time (falling edge of TCLK) of odd frames for insertion into the outgoing data stream (193E-FDL insertion). Sampled during the F-bit time of even frames for insertion into the outgoing data (193S-External S-Bit insertion).
11	TLCLK	O	Transmit Link Clock. 4 KHz demand clock for TLINK input.
12 13	TPOS TNEG	O	Transmit Bipolar Data Outputs. Updated on rising edge of TCLK.

PORT PIN DESCRIPTION (40–PIN DIP ONLY) Table 2

PIN	SYMBOL	TYPE	DESCRIPTION
14	$\overline{\text{INT}}^1$	O	Receive Alarm Interrupt. Flags host controller during alarm conditions. Active low, open drain output.
15	SDI ¹	I	Serial Data In. Data for onboard registers. Sampled on rising edge of SCLK.
16	SDO ¹	O	Serial Data Out. Control and status information from onboard registers. Updated on falling edge of SCLK, tri-stated during serial port write or when $\overline{\text{CS}}$ is high.
17	$\overline{\text{CS}}^1$	I	Chip Select. Must be low to write or read the serial port registers.
18	SCLK ¹	I	Serial Data Clock. Used to write or read the serial port registers.
19	SPS	I	Serial Port Select. Tie to V_{DD} to select serial port. Tie to V_{SS} to select hardware mode.

NOTE:

1. Multifunction pins. See "Hardware Mode Description."

POWER AND TEST PIN DESCRIPTION (40–PIN DIP ONLY) Table 3

PIN	SYMBOL	TYPE	DESCRIPTION
20	V _{SS}	–	Signal Ground. 0.0 volts.
32	TEST	I	Test Mode. Tie to V _{SS} for normal operation.
40	V _{DD}	–	Positive Supply. 5.0 volts.

RECEIVE PIN DESCRIPTION (40–PIN DIP ONLY) Table 4

PIN	SYMBOL	TYPE	DESCRIPTION
21	RYEL	O	Receive Yellow Alarm. Transitions high when yellow alarm detected, goes low when alarm clears.
22	RLINK	O	Receive Link Data. Updated with extracted FDL data one RCLK before start of odd frames (193E) and held until next update. Updated with extracted S-bit data one RCLK before start of even frames (193S) and held until next update.
23	RLCLK	O	Receive Link Clock. 4 KHz demand clock for RLINK.
24	RCLK	I	Receive Clock. 1.544 MHz primary clock.
25	RCHCLK	O	Receive Channel Clock. 192 KHz clock identifies time slot (channel) boundaries.
26	RSER	O	Receive Serial Data. Received NRZ serial data, updated on rising edges of RCLK.
27	RFSYNC	O	Receive Frame Sync. Extracted 8 KHz clock, one RCLK wide, indicates F-Bit position in each frame.
28	RMSYNC	O	Receive Multiframe Sync. Extracted multiframe sync; edge indicates start of multiframe, 50% duty cycle.
29	RABCD	O	Receive ABCD Signaling. Extracted signaling data output, valid for each channel time in signaling frames. In non-signaling frames, RABCD outputs the LSB of each channel word.
30	RSIGFR	O	Receive Signaling Frame. High during signaling frames, low during resync and non-signaling frames.
31	RSIGSEL	O	Receive Signaling Select. In 193E framing a .667 KHz clock which identifies signaling frames A and C. A 1.33 KHz clock in 193S.
33	RST	I	Reset. A high-low transition clears all internal registers and resets receive side counters. A high-low-high transition will initiate a receive resync.
34 35	RPOS RNEG	I	Receive Bipolar Data Inputs. Samples on falling edge of RCLK. Tie together to receive NRZ data and disable bipolar violation monitoring circuitry.
36	RCL	O	Receive Carrier Loss. High if 32 consecutive 0's appear at RPOS and RNEG; goes low after next 1.
37	RBV	O	Receive Bipolar Violation. High during accused bit time at RSER if bipolar violation detected, low otherwise.
38	RFER	O	Receive Frame Error. High during F-Bit time when F _T or F _S errors occur (193S) or when FPS or CRC errors occur (193E). Low during resync.
39	RLOS	O	Receive Loss of Sync. Indicates sync status; high when internal resync is in progress, low otherwise.

REGISTER SUMMARY Table 5

REGISTER	ADDRESS	T/R ¹	DESCRIPTION/FUNCTION
RSR	0000	R ²	Receive Status Register. Reports all receive alarm conditions.
RIMR	0001	R	Receive Interrupt Mask Register. Allows masking of individual alarm-generated interrupts.
BVCR	0010	R	Bipolar Violation Count Register. 8-bit presettable counter which records individual bipolar violations.
ECR	0011	R	Error Count Register. Two independent 4-bit counters which record OOF occurrences and individual frame bit or CRC errors.
CCR ³	0100	T/R	Common Control Register. Selects device operating characteristics common to receive and transmit sides.
RCR ³	0101	R	Receive Control Register. Programs device operating characteristics unique to the receive side.
TCR ³	0110	T	Transmit Control Register. Selects additional transmit side modes.
TIR1 TIR2 TIR3	0111 1000 1001	T T T	Transmit Idle Registers. Designate which outgoing channels are to be substituted with idle code.
TTR1 TTR2 TTR3	1010 1011 1100	T T T	Transmit Transparent Registers. Designate which outgoing channels are to be treated transparently. (No robbed bit signaling or bit 7 zero insertion.)
RMR1 RMR2 RMR3	1101 1110 1111	R R R	Receive Mark Registers. Designate which incoming channels are to be replaced with idle or digital milliwatt codes (under control of RCR).

NOTES:

1. Transmit or receive side register.
2. RSR is a read only register; all other registers are read/write.
3. Reserved bit locations in the control registers should be programmed to 0 to maintain compatibility with future transceiver products.

SERIAL PORT INTERFACE

Pins 14 through 18 of the DS2180A serve as a microprocessor/microcontroller-compatible serial port. Sixteen onboard registers allow the user to update operational characteristics and monitor device status via host controller, minimizing hardware interfaces. Port read/write timing is unrelated to the system transmit and receive timing, allowing asynchronous reads and/or writes by the host.

ADDRESS/COMMAND

Reading or writing the control, configuration or status registers requires writing one address command byte prior to transferring register data. The first bit written (LSB) of the address/command word specifies register read or write. The following 4-bit nibble identifies regis-

ter address. The next two bits are reserved and must be set to 0 for proper operation. The last bit of the address/command word enables burst mode when set; the burst mode causes all registers to be consecutively written or read. *Data is written to and read from the transceiver LSB first.*

CHIP SELECT AND CLOCK CONTROL

All data transfers are initiated by driving the \overline{CS} input low. Input data is latched on the rising edge of SCLK and *must be valid during the previous low period of SCLK to prevent momentary corruption of register data during writes.* Data is output on the falling edge of SCLK and held on the next falling edge. All data transfers are terminated if the \overline{CS} input transitions high. Port control logic is disabled and SDO is tri-stated when \overline{CS} is high.

DATA I/O

Following the eight SCLK cycles that input an address/command byte to write, a data byte is strobed into the addressed register on the rising edges of the next eight SCLK cycles. Following an address/command word to read, contents of the selected register are output on the falling edges of the next eight SCLK cycles. The SDO pin is tri-stated during device write and may be tied to SDI in applications where the host processor has a bidirectional I/O pin.

BURST MODE

The burst mode allows all onboard registers to be consecutively read and written by the host processor. A burst read is used to poll all registers; RSR contents will be unaffected. This feature minimizes device initialization time on power-up or system reset. Burst mode is initiated when ACB.7 is set and the address nibble is 0000. Burst is terminated by a low-high transition on CS.

ACB: ADDRESS COMMAND BYTE Figure 2

(MSB)								(LSB)
BM	–	–	ADD3	ADD2	ADD1	ADD0	R/W	
SYMBOL	POSITION	NAME AND DESCRIPTION						
BM	ACB.7	Burst Mode. If set (and ACB.1 through ACB.4=0) burst read or write is enabled.						
–	ACB.6	Reserved, must be 0 for proper operation.						
–	ACB.5	Reserved, must be 0 for proper operation.						
ADD3	ACB.4	MSB of register address.						
ADD0	ACB.1	LSB of register address.						
R/W	ACB.0	Read/Write Select. 0 = write addressed register. 1 = read addressed register.						

SERIAL PORT READ/WRITE Figure 3

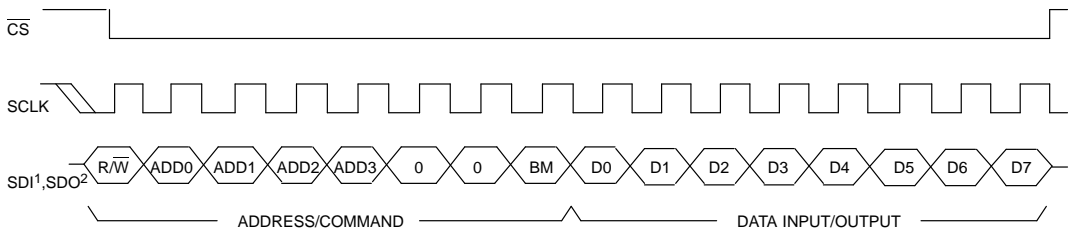

NOTES:

1. SDI sampled on rising edge of SCLK.
2. SDO updated on falling edge of SCLK.

COMMON CONTROL REGISTER Figure 4

(MSB)				(LSB)			
–	FRSR2	EYELMD	FM	SYELMD	B8ZS	B7	LPBK
SYMBOL	POSITION	NAME AND DESCRIPTION					
–	CCR.7	Reserved, must be 0 for proper operation.					
FRSR2	CCR.6	Function of REC Status Register 2. 0 = Detected B8ZS code words reported at RSR.2. 1 = COFA (Change-of-Frame Alignment) reported at RSR.2 when last re-sync resulted in change of frame or multiframe alignment.					
EYELMD	CCR.5	193E Yellow Mode Select. 0 = Yellow alarm is a repeating pattern set of 00 hex and FF hex. 1 = Yellow alarm is a 0 in the bit 2 position of all channels.					
FM	CCR.4	Frame Mode Select. 0 = D4 (193S, 12 frames/superframe). 1 = Extended (193E, 24 frames/superframe).					
SYELMD	CCR.3	193S Yellow Mode Select. Determines yellow alarm type to be transmitted and detected while in 193S framing. If set, yellow alarms are a 1 in the S-bit position of frame 12; if cleared, yellow alarm is a 0 in bit 2 of all channels. Does not affect 193E yellow alarm operation.					
B8ZS	CCR.2	Bipolar eight zero substitution. 0 = No B8ZS. 1 = B8ZS enabled. (Note: This bit must be set to 0 when CCR.1=1)					
B7	CCR.1	Bit seven zero suppression. If CCR.1=1, channels with an all zero content will be transmitted with bit 7 forced to 1. If CCR.1=0, no bit 7 stuffing occurs. (Note: This bit must be set to 0 when CCR.2=1)					
LPBK	CCR.0	Loopback. When set, the device internally loops output transmit data into the incoming receive data buffers and TCLK is internally substituted for RCLK.					

LOOPBACK (Refer to Figure 4)

Enabling loopback will typically induce an out-of-frame (OOF) condition. If appropriate bits are set in the receive control register, the receiver will resync to the looped transmit frame alignment. During the looped condition, the transmit outputs (TPOS, TNEG) will transmit unframed all 1's. All operating modes (B8ZS, alarm, signaling, etc.) except for blue alarm transmission are available in loopback.

BIT SEVEN STUFFING

Existing systems meet 1's density requirements by forcing bit 7 of all zero channels to 1. Bit 7 stuffing is globally enabled by asserting bit CCR.1 and may be disabled on an individual channel basis by setting appropriate bits in TTR1–TTR3. Bit 7 stuffing and B8ZS modes should not be enabled simultaneously. Enabling both results in LOS.

B8ZS

The DS2180A supports existing and emerging zero suppression formats. Selection of B8ZS coding maintains system 1's density requirements without disturbing data integrity as required in emerging clear channel

applications. B8ZS coding replaces eight consecutive outgoing 0's with a B8ZS code word. Any received B8ZS code word is replaced with all 0's. B8ZS and bit 7 stuffing modes should not be enabled simultaneously. Enabling both results in LOS.

TCR: TRANSMIT CONTROL REGISTER Figure 5

(MSB)								(LSB)
ODF	TFPT	TCP	RBSE	TIS	193SI	TBL	TYEL	
SYMBOL	POSITION	NAME AND DESCRIPTION						
ODF	TCR.7	Output Data Format. 0 = Bipolar data at TPOS and TNEG. 1 = NRZ data at TPOS; TNEG=0.						
TFPT	TCR.6	Transmit Framing Pass-through. 0 = FT/FPS sourced internally. 1 = FT/FPS sampled at TSER during F-bit time.						
TCP	TCR.5	Transmit CRC Pass-through. 0 = Transmit CRC code internally generated. 1 = TSER sampled at CRC F-bit time for external CRC insertion.						
RBSE	TCR.4	Robbed Bit Signaling Enable. 1 = Signaling inserted in all channels during signaling frames. 0 = No signaling inserted. (The TTR registers allow the user to disable signaling insertion on selected DS0 channels.)						
TIS	TCR.3	Transmit Idle Code Select. Determines idle code format to be inserted into channels marked by the TIR registers. 0 = Insert 7F (Hex) into marked channels. 1 = Insert FF (Hex) into marked channels.						
193SI	TCR.2	193S S-bit Insertion. Determines source of transmitted S-bit. 0 = Internal S-bit generator. 1 = External (sampled at TLINK input).						
TBL	TCR.1	Transmit Blue Alarm. 0 = Disabled. 1 = Enabled.						
TYEL	TCR.0	Transmit Yellow Alarm. 0 = Disabled. 1 = Enabled.						

TRANSMIT BLUE ALARM

The blue alarm (also known as the AIS, Alarm Indication Signal) is an unframed, all 1's sequence enabled by asserting TCR.1. Blue alarm overrides all other transmit data patterns and is disabled by clearing TCR.1. Use of the TIR registers allows a framed, all 1's alarm transmission if required by the network.

TRANSMIT YELLOW ALARM

In 193E framing, a yellow alarm is a repeating pattern set of FF(Hex) and 00 (Hex) on the 4 KHz facility data link (FDL). In 193S framing the yellow alarm format is dependent on the state of bit CCR.3. In all modes, yellow alarm is enabled by asserting TCR.0 and disabled by clearing TCR.0.

TRANSMIT SIGNALING

When enabled (via TCR.4) channel signaling is inserted in frames 6 and 12 (193S) or in frames 6, 12, 18 and 24 (193E) in the 8th bit position of every channel word. Signaling data is sampled at TABCD on the falling edge

of TCLK during bit 8 of each input word during signaling frames. Logical combination of clocks TMO, TSIGFR and TSIGSEL allows external multiplexing of separate serial links for A, B or A, B, C, D signaling sources.

TTR1–TTR3: TRANSMIT TRANSPARENCY REGISTERS Figure 6

(MSB)								(LSB)
CH8	CH7	CH6	CH5	CH4	CH3	CH2	CH1	TTR1
CH16	CH15	CH14	CH13	CH12	CH11	CH10	CH9	TTR2
CH24	CH23	CH22	CH21	CH20	CH19	CH18	CH17	TTR3

SYMBOL	POSITION	NAME AND DESCRIPTION
CH24	TTR3.7	Transmit Transparent Registers. Each of these bit positions represents a DS0 channel in the outgoing frame. When set, the corresponding channel is transparent.
CH1	TTR1.0	

TIR1–TIR3: TRANSMIT IDLE REGISTERS Figure 7

(MSB)								(LSB)
CH8	CH7	CH6	CH5	CH4	CH3	CH2	CH1	TIR1
CH16	CH15	CH14	CH13	CH12	CH11	CH10	CH9	TIR2
CH24	CH23	CH22	CH21	CH20	CH19	CH18	CH17	TIR3

SYMBOL	POSITION	NAME AND DESCRIPTION
CH24	TIR3.7	Transmit Idle Registers. Each of these bit positions represents a DS0 channel in the outgoing frame. When set, the corresponding channel will output an idle code format determined by TCR.2.
CH1	TIR1.0	

TRANSMIT CHANNEL TRANSPARENCY

Individual DS0 channels in the T1 frame may be programmed clear (no inserted robbed bit signaling and no bit 7 zero suppression) by setting the appropriate bits in the transmit transparency registers. Channel transparency is required in mixed voice/data or data-only environments such as ISDN, where data integrity must be maintained.

TRANSMIT IDLE CODE INSERTION

Individual outgoing channels in the frame can be programmed with idle code by asserting the appropriate bits in the transmit idle registers. One of two idle code formats, 7F (Hex) and FF (Hex) may be selected by the user via TCR.3. If enabled, robbed bit signaling data is inserted into the idle channel, unless the appropriate TTR bit is set for that channel. This feature eliminates external hardware currently required to intercept and stuff unoccupied channels in the DS1 bit stream.

193S TRANSMIT MULTIFRAME TIMING Figure 9

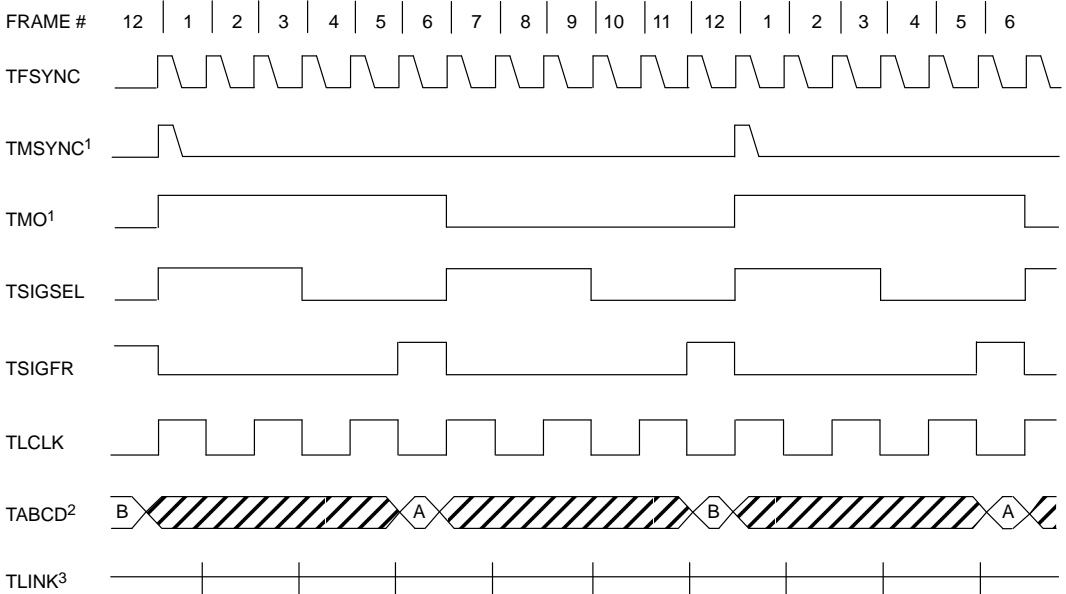

NOTES:

- Transmit frame and multiframe timing may be established in one of four ways:
 - With TFSYNC tied low, TMSYNC may be pulsed high once every multiframe period to establish multiframe boundaries, allowing internal counters to determine frame timing.
 - TFSYNC may be pulsed every 125 microseconds; pulsing TMSYNC once establishes multiframe boundaries.
 - TMSYNC and TFSYNC may be continuously pulsed to establish and reinforce frame and superframe timing.
 - If TMSYNC is tied low and TFSYNC is pulsed at frame boundaries, the transmitter will establish an arbitrary multiframe boundary as indicated by TMO.
- Channels in which robbed bit signaling is enabled will sample TABCD during the LSB bit time in frames indicated.
- When external S-bit insertion is enabled, TLINK will be sampled during the F-bit time of even frames and inserted into the outgoing data stream.

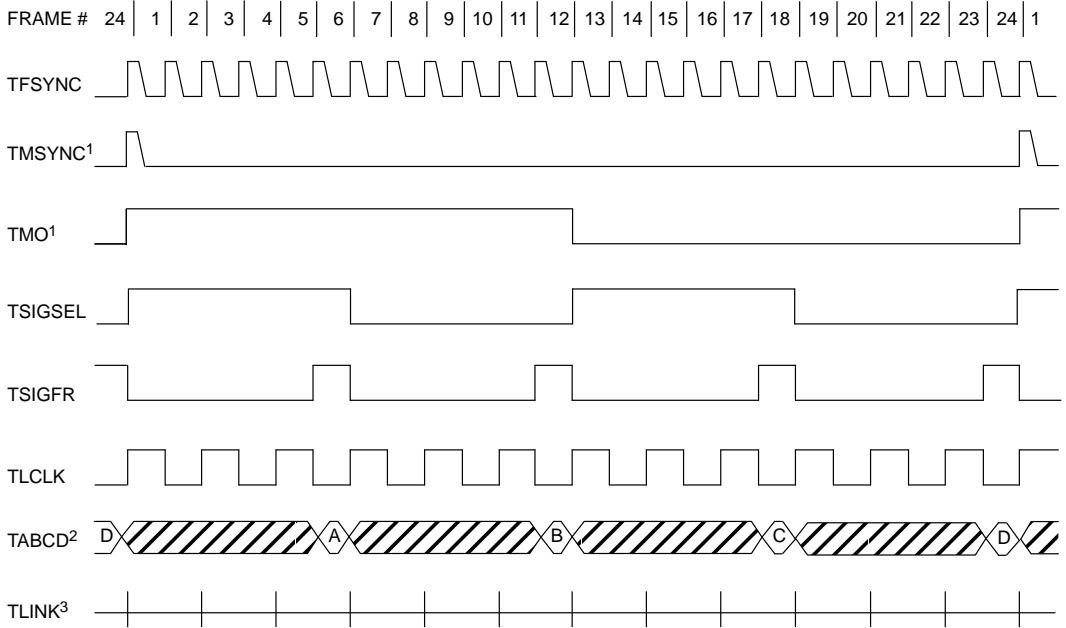
193E TRANSMIT MULTIFRAME TIMING Figure 10**NOTES:**

- Transmit frame and multiframe timing may be established in one of four ways:
 - With TFSYNC tied low, TMSYNC may be pulsed high once every multiframe period to establish multiframe boundaries, allowing internal counters to determine frame timing.
 - TFSYNC may be pulsed every 125 microseconds; pulsing TMSYNC once establishes multiframe boundaries.
 - TMSYNC and TFSYNC may be continuously pulsed to establish and reinforce frame and superframe timing.
 - If TMSYNC is tied low and TFSYNC is pulsed at frame boundaries, the transmitter will establish an arbitrary multiframe boundary as indicated by TMO.
- Channels in which robbed bit signaling is enabled will sample TABCD during the LSB bit time in frames indicated.
- TLINK is sampled during the F-bit time of odd frames and inserted into the outgoing data stream (FDL data).

TRANSMIT MULTIFRAME BOUNDARY TIMING Figure 11

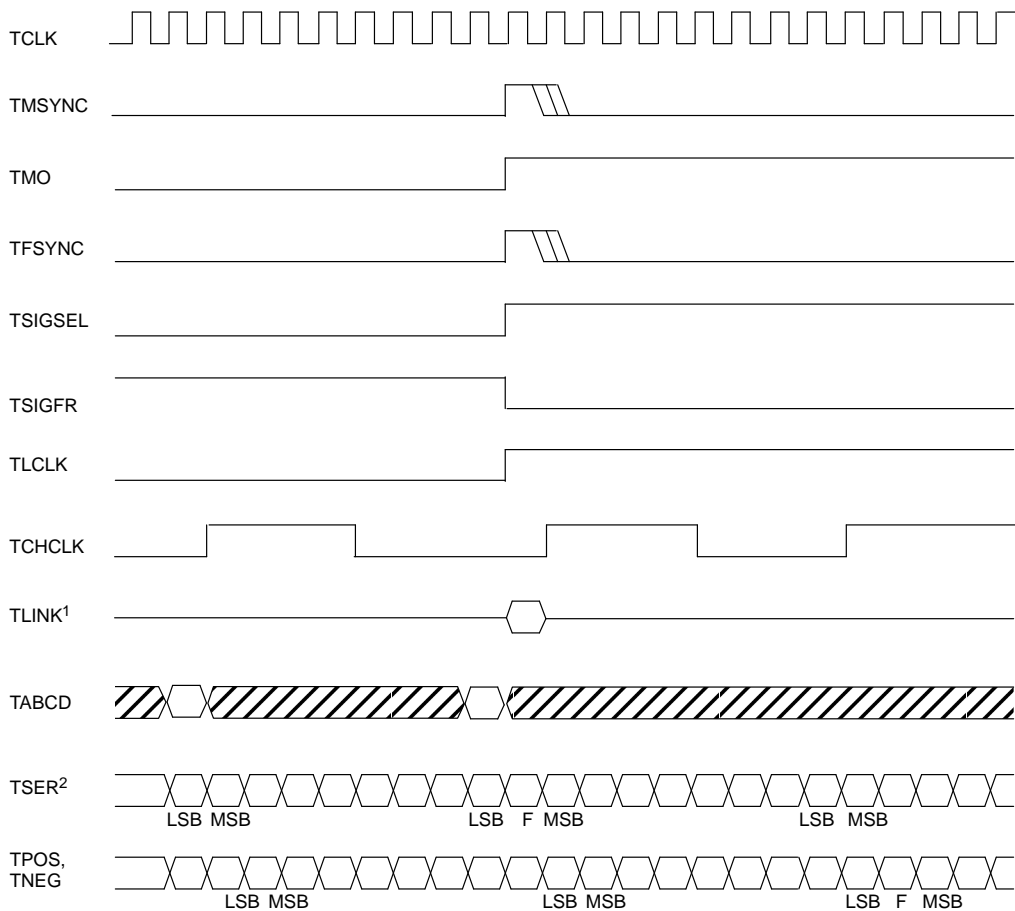

NOTES:

1. TLINK timing shown is for 193E framing; in 193E framing, TLINK is sampled as indicated for insertion into F-bit position of odd frames. When S-bit insertion is enabled in 193S, TLINK is sampled during even frames.
2. If TCR.5=1, TSER is sampled during the F-bit time of CRC frames for insertion into the outgoing data stream (193E framing only).

RECEIVE CONTROL REGISTER Figure 12

(MSB)				(LSB)			
ARC	OOF	RCI	RCS	SYNCC	SYNCT	SYNCE	RESYNC
SYMBOL	POSITION	NAME AND DESCRIPTION					
ARC	RCR.7	Auto Resync Criteria. 0 = Resync on OOF or RCL event. 1 = Resync on OOF only.					
OOF	RCR.6	Out-of-frame (OOF) Condition Detection. 0 = 2 of 4 framing bits in error. 1 = 2 of 5 framing bits in error.					
RCI	RCR.5	Receive Code Insert. When set, the receive code selected by RCR.4 is inserted into channels marked by RMR registers. If clear, no code is inserted.					
RCS	RCR.4	Receive Code Select. 0 = Idle code (7F Hex). 1 = Digital milliwatt.					
SYNCC	RCR.3	Sync Criteria. Determines the type of algorithm utilized by the receive synchronizer and differs for each frame mode. 193S Framing (CCR.4=0). 0 = Synchronize to frame boundaries using F_T pattern, then search for multiframe by using F_S . 1 = Cross couple F_T and F_S patterns in sync algorithm. 193E Framing (CCR.4=1). 0 = Normal sync (utilizes FPS only). 1 = Validate new alignment with CRC before declaring sync.					
SYNCT	RCR.2	Sync Time. If set, 24 consecutive F-bits of the framing pattern must be qualified before sync is declared. If clear, 10 bits are qualified.					
SYNCE	RCR.1	Sync Enable. If clear, the transceiver will automatically begin a resync if two of the previous four or five framing bits were in error or if carrier loss is detected. If set, no auto resync occurs.					
RESYNC	RCR.0	Resync. When toggled low to high, the transceiver will initiate resync immediately. The bit must be cleared, then set again for subsequent resyncs.					

RECEIVE CODE INSERTION

Incoming receive channels can be replaced with idle (7F Hex) or digital milliwatt (μ -LAW format) codes. The receive mark registers indicate which channels are inserted. When set, bit RCR.5 serves as a "global" enable for marked channels and bit RCR.4 selects inserted code format: 0 = idle code, 1 = digital milliwatt.

RECEIVE SYNCHRONIZER

Bits RCR.0 through RCR.3 allow the user to control operational characteristics of the synchronizer. Sync algorithm, candidate qualify testing, auto resync, and command resync modes may be altered at any time in response to changing span conditions.

RECEIVE SIGNALING

Robbed bit signaling data is presented at RABCD during each channel time in signaling frames for all 24 in-

coming channels. Logical combination of clocks RMSYNC, RSIGFR and RSIGSEL allow the user to identify and extract AB or ABCD signaling data.

RMR1–RMR3: RECEIVE MARK REGISTERS Figure 13

(MSB)								(LSB)
CH8	CH7	CH6	CH5	CH4	CH3	CH2	CH1	RMR1
CH16	CH15	CH14	CH13	CH12	CH11	CH10	CH9	RMR2
CH24	CH23	CH22	CH21	CH20	CH19	CH18	CH17	RMR3

SYMBOL	POSITION	NAME AND DESCRIPTION
CH24	RMR3.7	Receive Mark Registers. Each of these bit positions represents a DS0 channel in the incoming T1 frame. When set, the corresponding channel will output codes determined by RCR.4 and RCR.5.
CH1	RMR1.0	

193S RECEIVE MULTIFRAME TIMING Figure 14

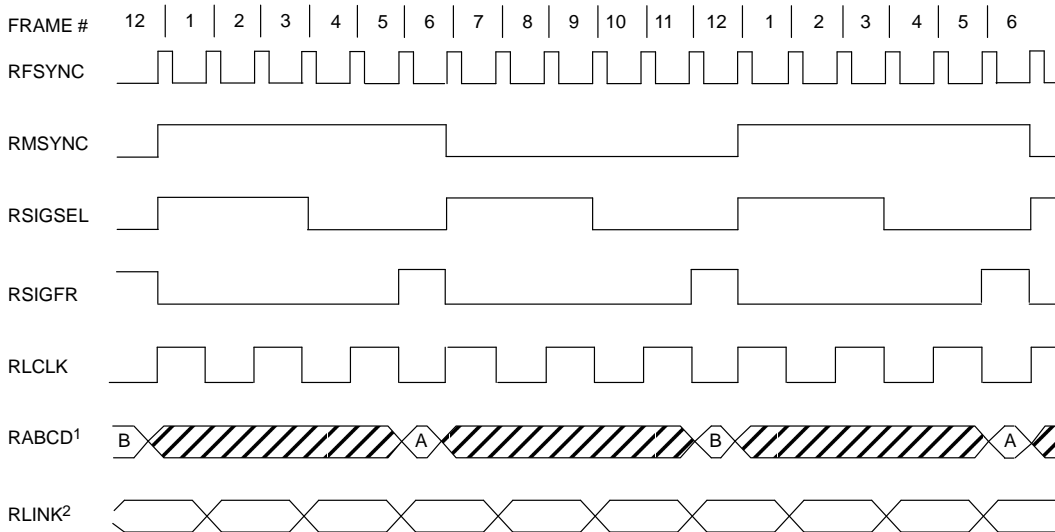

NOTES:

1. Signaling data is updated during signaling frames on channel boundaries. RABCD is the LSB of each channel word in non-signaling frames.
2. RLINK data (S-bit) is updated one bit time prior to S-bit frames and held for two frames.

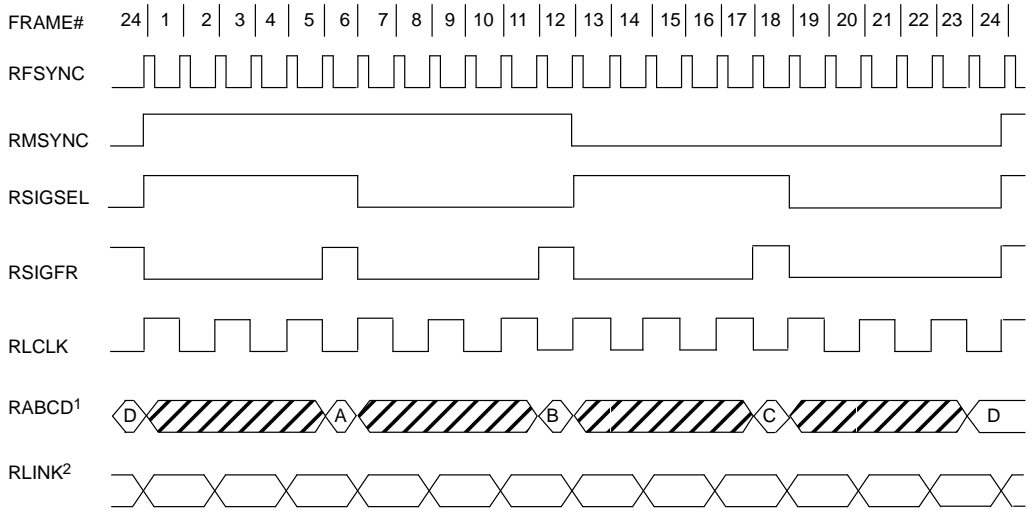
193E RECEIVE MULTIFRAME TIMING Figure 15**NOTES:**

1. Signaling data is updated during signaling frames on channel boundaries. RABCD outputs the LSB of each channel word in non-signaling frames.
2. RLINK data (FDL-bit) is updated one bit time prior to odd frames and held for two frames.

RECEIVE MULTIFRAME BOUNDARY TIMING Figure 16

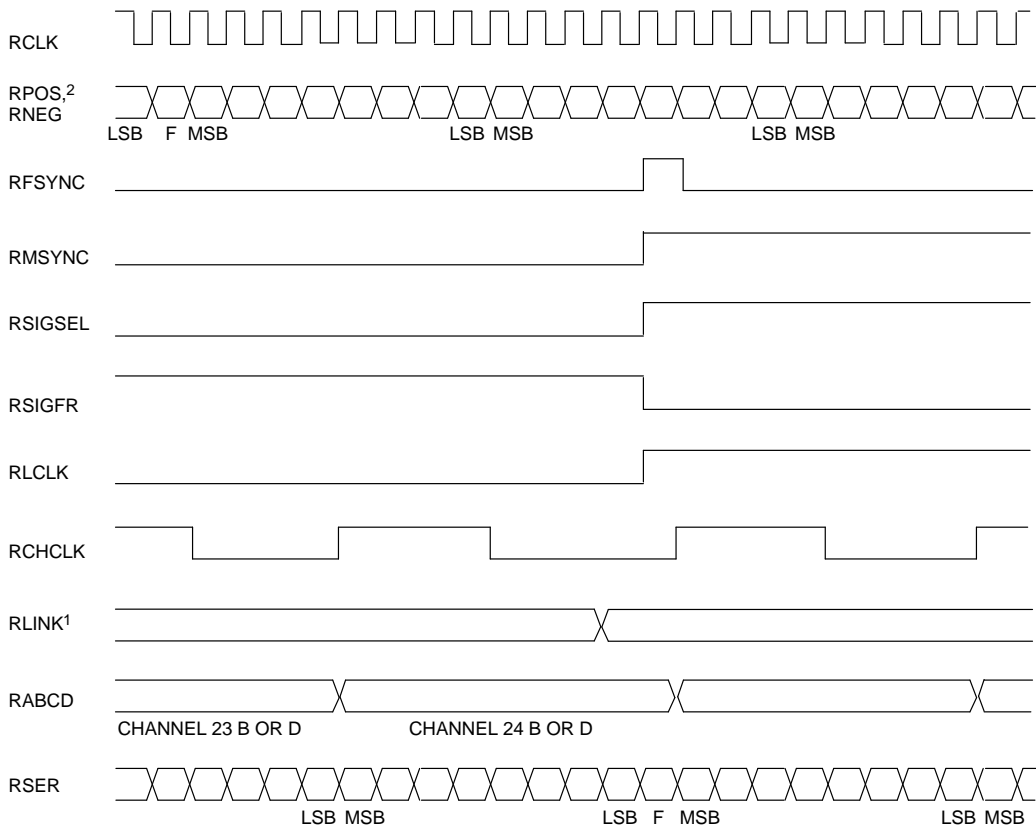

NOTES:

1. RLINK timing is shown for 193E; in 193S, RLINK is updated on even frame boundaries and is held across multiframe edges.
2. Total delay from RPOS and RNEG to RSER output is 13 RCLK periods.

RSR: RECEIVE STATUS REGISTER Figure 17

(MSB)				(LSB)			
BVCS	ECS	RYEL	RCL	FERR	B8ZSD	RBL	RLOS
SYMBOL	POSITION	NAME AND DESCRIPTION					
BVCS	RSR.7	Bipolar Violation Count Saturation. Set when the 8-bit counter at BVCR saturates.					
ECS	RSR.6	Error Count Saturation. Set when either of the 4-bit counters at ECR saturates.					
RYEL	RSR.5	Receive Yellow Alarm. Set when yellow alarm detected. (Detected yellow alarm format determined by CCR.4 and CCR.3.)					
RCL	RSR.4	Receive Carrier Loss. Set when 32 consecutive 0's appear at RPOS and RNEG.					
FERR	RSR.3	Frame Bit Error. Set when F_T (193S) or FPS (193E) bit error occurs.					
B8ZSD	RSR.2	Bipolar Eight Zero Substitution Detect. Set when B8ZS code word detected.					
RBL	RSR.1	Receive Blue Alarm. Set when two consecutive frames have less than three 0's (total) in the data stream (F-bit positions not tested).					
RLOS	RSR.0	Receive Loss of Sync. Set when resync is in process; if RCR.1=0, RLOS transitions high on an OOF event or carrier loss indicating auto resync.					

RECEIVE ALARM REPORTING

Incoming serial data is monitored by the transceiver for alarm occurrences. Alarm conditions are reported in two ways: via transitions on the alarm output pins and registered interrupt, in which the host controller reads the RSR in response to an alarm-driven interrupt. Interrupts may be direct, in which the transceiver demands service for a real-time alarm, or count-overflow triggered, in which an onboard alarm event counter exceeds a user-programmed threshold. The user may mask individual alarm conditions by clearing the appropriate bits in the receive interrupt mask register (RIMR).

ALARM SERVICING

The host controller must service the transceiver in order to clear an interrupt condition. Clearing appropriate bits in the RIMR will unconditionally clear an interrupt. Direct interrupt (those driven from real-time alarms) will be cleared when the RSR is directly read unless the alarm condition still exists. Count-overflow interrupts (BVCS, ECS) are not cleared by a direct read of the RSR. They will be cleared only when the user presets the appropriate count register to a value other than all 1's. A burst read of the RSR will not clear an interrupt condition.

RIMR: RECEIVE INTERRUPT MASK REGISTER Figure 18

(MSB)				(LSB)			
BVCS	ECS	RYEL	RCL	FERR	B8ZSD	RBL	RLOS
SYMBOL	POSITION	NAME AND DESCRIPTION					
BVCS	RIMR.7	Bipolar Violation Count Saturation Mask. 1 = Interrupt masked. 0 = Interrupt masked.					
ECS	RIMR.6	Error Count Saturation Mask. 1 = Interrupt enabled. 0 = Interrupt masked.					
RYEL	RIMR.5	Receive Yellow Alarm Mask. 1 = Interrupt enabled. 0 = Interrupt masked.					
RCL	RIMR.4	Receive Carrier Loss Mask. 1 = Interrupt enabled. 0 = Interrupt masked.					
FERR	RIMR.3	Frame Bit Error Mask. 1 = Interrupt enabled. 0 = Interrupt masked.					
B8ZSD	RIMR.2	B8ZS Detect Mask. 1 = Interrupt enabled. 0 = Interrupt masked.					
RBL	RIMR.1	Receive Blue Alarm Mask. 1 = Interrupt enabled. 0 = Interrupt masked.					
RLOS	RIMR.0	Receive Loss of Sync Mask. 1 = Interrupt enabled. 0 = Interrupt masked.					

ALARM COUNTERS

The three onboard alarm event counters allow the transceiver to monitor and record error events without processor intervention on each event occurrence. All of these counters are presettable by the user establishing an event count interrupt threshold. As each counter saturates, the next error event occurrence will set a bit in the RSR and generate an interrupt unless masked. The user may read these registers at any time; in many systems, the host will periodically poll these registers to establish link error rate performance.

OOF EVENTS AND ERRORED SUPERFRAMES

Out of frame is declared when at least two of four (or five) consecutive framing bits are in error. F_T bits are tested for OOF occurrence in 193S; the FPS bits are tested in 193E. OOF events are recorded by the 4-bit OOF counter in the error counter register. In the 193E framing mode, the OOF event is logically OR'ed with an on-chip generated CRC checksum. This event, known as errored superframe, is recorded by the 4-bit ESF error counter in the error count register. In the 193S framing mode, the 4-bit ESF error counter records individual F_T and F_S errors when $R_{CR.3}=1$ or F_T errors only when $R_{CR.3}=0$.

BVCR: BIPOLAR VIOLATION COUNT REGISTER Figure 19

(MSB)				(LSB)			
BVD7	BVD6	BVD5	BVD4	BVD3	BVD2	BVD1	BVD0
SYMBOL	POSITION	NAME AND DESCRIPTION					
BVD7	BVCR.7	MSB of bipolar count.					
BVD0	BVCR.0	LSB of bipolar count.					

This 8-bit binary up counter saturates at 255 and will generate an interrupt for each occurrence of a bipolar violation once saturated (RIMR.7=1). Presetting this register allows the user to establish specific count interrupt thresholds. The counter will count "up" to saturation

from the preset value and may be read at any time. Counter increments occur at all times and are not disabled by resync. If B8ZS is enabled (CCR.2=1) bipolar violations are not counted for B8ZS code words.

ECR: ERROR COUNT REGISTER Figure 20

(MSB)				(LSB)			
OOFD3	OOFD2	OOFD1	OOFD0	ESFD3	ESFD2	ESFD1	ESFD0
← ERROR COUNT →				← ESF ERROR COUNT →			
SYMBOL	POSITION	NAME AND DESCRIPTION					
OOFD3	ECR.7	MSB of OOF event count.					
OOFD0	ECR.4	LSB of OOF event count.					
ESFD3	ECR.3	MSB of extended superframe error count.					
ESFD0	ECR.0	LSB of extended superframe error count.					

These separate 4-bit binary up counters saturate at a count of 15 and will generate an interrupt for each occurrence of an OOF event or an ESF error event after saturation (RIMR.6=1). Presetting these counters allows the user to establish specific count interrupt thresholds. The counters will count "up" to saturation from the preset value and may be read at any time. These counters share the same register address and must be written to or read from simultaneously.

The OOF counter records out-of-frame events in both 193S and 193E. The ESF error counter records errored superframes in 193E. In 193S, the ESF counter records individual F_T and F_S errors when RCR.3=1; F_T errors only when RCR.3=0. ECR counter increments are disabled when resync is in progress (RLOS high).

ALARM OUTPUTS

The transceiver also provides direct alarm outputs for applications when additional decoding and demuxing are required to supplement the onboard alarm logic.

RLOS OUTPUT

The receive loss of sync output indicates the status of the receiver synchronizer circuitry; when high, an off-line resynchronization is in progress and a high-low transition indicates resync is complete. The RLOS bit (RSR.0) is a "latched" version of the RLOS output. If the auto-resync mode is selected (RCR.1=0), RLOS is a real time indication of a carrier loss or OOF event occurrence.

RYEL OUTPUT

The yellow alarm output transitions high when a yellow alarm is detected. A high-low transition indicates the alarm condition has been cleared. The RYEL bit (RSR.5) is a "latched" version of the RYEL output. In 193E framing, the yellow alarm pattern detected is 16 pattern sets of 00 (Hex) and FF (Hex) received at RLINK. In 193S, framing the yellow alarm format is dependent on CCR.3; if CCR.3=0, the RYEL output transitions high if bit 2 of 256 or more consecutive channels is 0; if CCR.3=1, yellow alarm is declared when the S-bit received in frame 12 is 1.

RBV OUTPUT

The bipolar violation output transitions high when an accused bit emerges at RSER. RBV will go low at the next bit time if no additional violations are detected.

RFER OUTPUT

The receive frame error output transitions high at the F-bit time and is held high for two bit periods when a frame bit error occurs. In 193S framing, F_T and F_S patterns are tested. The FPS pattern is tested in 193E framing. Additionally, in 193E framing, RFER reports a CRC error by a low-high-low transition (one bit period wide) one half RCLK period before a low-high transition on RMSYNC.

RESET

A high-low transition on \overline{RST} clears all registers and forces immediate receive resync when \overline{RST} returns high. This reset has no effect on transmit frame multi-frame or channel counters. \overline{RST} must be held low on system power-up to insure proper initialization of transceiver counters and registers. Following reset, the host processor should restore all control modes by writing appropriate registers with control data.

ALARM OUTPUT TIMING Figure 21

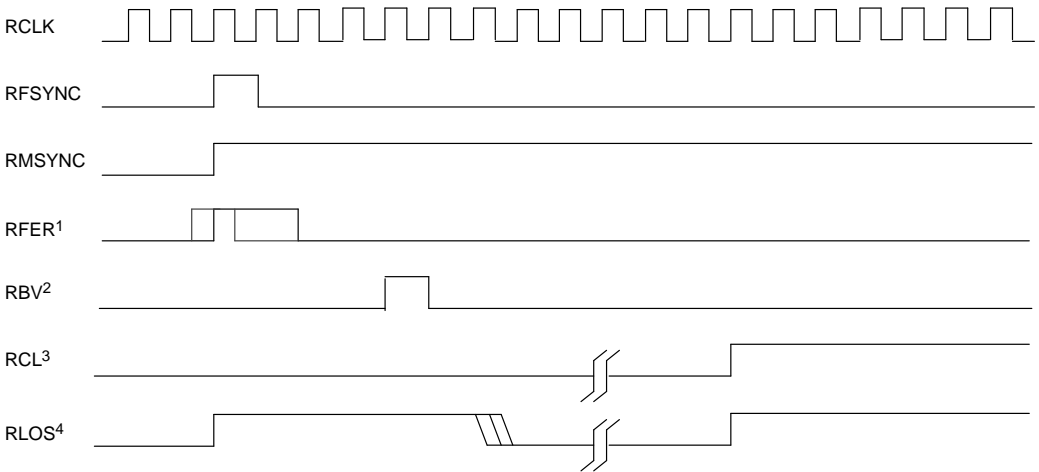

NOTES:

1. RFER transitions high during F-bit time if received framing pattern bit is in error. (Frame 12 F-bits in 193S are ignored if CCR.3=1). Also, in 193E, RFER transitions 1/2 bit time before the rising edge of RMSYNC to indicate a CRC error for the previous multiframe.
2. RBV indicates received bipolar violation and transitions high when an accused bit emerges from RSER. If B8ZS is enabled, RBV will not report the zero replacement code.
3. RCL transitions high (during 32nd bit time) when 32 consecutive bits received are 0; RCL transitions low when the next 1 is received.
4. RLOS transitions high during the F-bit time that caused an OOF event (any two of four consecutive F_T or FPS bits are in error) if auto-resync mode is selected (RCR.1=0). Resync will also occur when loss of carrier is detected (RCL=1). When RCR.1=1, RLOS remains low until resync occurs, regardless of OOF or carrier loss flags. In this situation, resync is initiated only when RCR.0 transitions low-to-high or the \overline{RST} pin transitions high-low-high.

HARDWARE MODE

For preliminary system prototyping or applications which do not require the features offered by the serial port, the transceiver can be reconfigured by the SPS pin. Tying SPS to V_{SS} disables the serial port, clears all internal registers except CCR and TCR and redefines pins 14 through 18 as mode control inputs. The hardware mode allows device retrofit into existing applications where mode control and alarm conditioning hardware is often designed with discrete logic.

HARDWARE COMMON CONTROL

In the hardware mode bits TCR.2, CCR.4, TCR.0, CCR.1 and CCR.2 map to pins 14 through 18. The loop-

back feature (bit CCR.0) is enabled by tying pins 17 (zero suppression) and 18 (B8ZS) to 1. (The last states of pins 17 and 18 are latched as when both pins are taken high, preserving the current zero suppression mode). Robbed bit signaling (bit TCR.4) is enabled for all channels. The user may tie TSER to TABCD externally to disable signaling if so desired. Bit CCR.3 is forced to 0 which selects bit 2 yellow alarm in 193S framing. Contents of the RCR, as well as the remaining bit locations in the CCR and TCR are cleared in the hardware mode. The RST input may be used to force immediate receiver resync and has no effect on transmit.

HARDWARE MODE Table 6

PIN NUMBER	REGISTER BIT LOCATION	NAME AND DESCRIPTION
14 (16)	TCR-D2	193S – S-bit insertion ³ 1 = external; 0 = internal
15 (17)	CCR-D4	Framing Mode Select. 1 = 193E; 0 = 193S
16 (18)	TCR-D0	Transmit Yellow Alarm ^{2,3} 1 = enabled; 0 = disabled
17 (19)	CCR-D1	Zero Suppression ¹ 1 = bit 7 stuffing 0 = transparent
18 (20)	CCR-D2	B8ZS ¹ . 1 = enabled; 0 = disabled

NOTES:

1. Tying pins 17 and 18 high enables loopback in the hardware mode.
2. Bit 2 (193S) and data link (193E) yellow alarms are supported.
3. S-bit yellow alarm (193S) is not internally supported; however, the user may elect to insert external S bits for alarm purposes.
4. Pin numbers for PLCC package are listed in parenthesis.

T1 OVERVIEW

Framing Standards

The DS2180A is compatible with the existing Bell System D4 framing standard described in ATT PUB 43801 and the new extended superframe format (ESF) as described in ATT C.B. #142. In this document, D4 framing is referred to as 193S and ESF (also known as Fe) is referred to as 193E. Programmable features of the DS2180A allow support of other framing standards which are derivatives of 193E and 193S. The salient differences between the 193S and 193E formats are the number of frames per superframe and use of the F-bit position. In 193S, 12 frames make up a superframe, in 193E, 24. A frame consists of 24 channels (timeslots) of 8-bit data preceded by an F-bit. Channel data is transmitted and received MSB first.

F-Bits

The use of the F-bit position in 193S is split between the terminal framing pattern (known as F_T -bits) which provides frame alignment information and the signaling framing pattern (known as F_S -bits) which provides multiframe alignment information. In 193E framing, the F-bit position is shared by the framing pattern sequence

(FPS) which provides frame and multiframe alignment information, a 4 KHz data link known as FDL (Facility Data Link), and CRC (Cyclic Redundancy Check) bits. The FDL bits are used for control and maintenance (inserted by the user at TLINK) and the CRC bits are an indicator of link quality and may be monitored by the user to establish error performance.

Signaling

During frames 6 and 12 in 193S, A and B signaling information is inserted into the LSB of all channels transmitted. In 193E, A and B data is inserted into frames 6 and 12 and C and D data is inserted into frames 18 and 24. This allows a maximum of four signaling states to be transmitted per superframe in 193S and 16 states in 193E.

Alarms

The DS2180A supports all alarm pattern generation and detection required in typical Bell System applications. These alarm modes are explained in ATT PUB 43801, ATT C.B. #142 and elsewhere in this document.

193E FRAMING FORMAT Table 7

FRAME NUMBER	F-BIT USE			BIT USE IN EACH CHANNEL		SIGNALING-BIT USE		
	FPS ¹	FDL ²	CRC ³	DATA	SIGNALING	2 STATE	4 STATE	16 STATE
1	–	M	–	BITS 1–8				
2	–	–	C1	BITS 1–8				
3	–	M	–	BITS 1–8				
4	0	–	–	BITS 1–8				
5	–	M	–	BITS 1–8				
6	–	–	C2	BITS 1–7	BIT 8	A	A	A
7	–	M	–	BITS 1–8				
8	0	–	–	BITS 1–8				
9	–	M	–	BITS 1–8				
10	–	–	C3	BITS 1–8				
11	–	M	–	BITS 1–8				
12	1	–	–	BITS 1–7	BIT 8	A	B	B
13	–	M	–	BITS 1–8				
14	–	–	C4	BITS 1–8				
15	–	M	–	BITS 1–8				
16	0	–	–	BITS 1–8				
17	–	M	–	BITS 1–8				
18	–	–	C5	BITS 1–7	BIT 8	A	A	C
19	–	M	–	BITS 1–8				
20	1	–	–	BITS 1–8				
21	–	M	–	BITS 1–8				
22	–	–	C6	BITS 1–8				
23	–	M	–	BITS 1–8				
24	1	–	–	BITS 1–7	BIT 8	A	B	D

NOTES:

1. FPS – Framing Pattern Sequence.
2. FDL – 4 KHz Facility Data Link; M = message bits.
3. CRC – Cyclic Redundancy Check bits. The CRC code will be internally generated by the device when TCR.5=0. When TCR.5=1, externally supplied CRC data will be sampled at TSER during the F-bit time of frames 2, 6, 10, 14, 18, 22.
4. The user may program any individual channels clear, in which case bit 8 will be used for data, not signaling.
5. Depending on application, the user can support 2-state, 4-state or 16-state signaling by the appropriate decodes of TMO, TSIGFR, TSIGSEL (Transmit Side) and RMSYNC, RSIGFR and RSIGSEL (Receive Side).

193S FRAMING FORMAT Table 8

FRAME NUMBER	F-BIT USE		BIT USE IN EACH CHANNEL		SIGNALING-BIT USE
	F_T^1	F_S^2	DATA	SIGNALING ⁴	
1	1	–	BITS 1–8	BIT 8	A
2	–	0	BITS 1–8		
3	0	–	BITS 1–8		
4	–	0	BITS 1–8		
5	1	–	BITS 1–8		
6	–	1	BITS 1–7		
7	0	–	BITS 1–8		
8	–	1	BITS 1–8		
9	1	–	BITS 1–8		
10	–	1	BITS 1–8		
11	0	–	BITS 1–8		
12	–	0 ³	BITS 1–7		

NOTES:

1. F_T (terminal framing) bits provide frame alignment information.
2. F_S (signaling frame) bits provide multiframe alignment information.
3. The S-bit in frame 12 may be used for yellow alarm transmission and detection in some applications.
4. The user may program any individual channels clear, in which case bit 8 will be used for data, not signaling.

Line Coding

T1 line data is transmitted in a bipolar alternative mark inversion line format; 1's are transmitted as alternating negative and positive pulses and 0's are simply the absence of pulses. This technique minimizes DC voltage on the T1 span and allows clock to be extracted from data. The network currently has a 1's density constraint to keep clock extraction circuitry functioning which is usually met by forcing bit 7 of any channel consisting of all 0's to 1. The use of Bipolar Eight Zero Substitution (B8ZS) satisfies all the 1's density requirement while allowing data traffic to be transmitted without corruption. This feature is known as clear channel and is explained more completely in ATT C.B. #144. When the B8ZS fea-

ture is enabled, any outgoing stream of eight consecutive 0's is replaced with a B8ZS code word. If the last 1 transmitted was positive, the inserted code is 000+-0-+; if negative, the code word inserted is 000-+0+-. Bipolar violations occur in the fourth and seventh bit positions which are ignored by the DS2180A error monitoring logic when B8ZS is enabled. Any received B8ZS code word is replaced with all 0's if B8ZS is enabled. Also, the receive status register will report any occurrence of B8ZS code words to the host controller. This allows the user to monitor the link for upgrade to clear channel capability and respond to it. The B8ZS monitoring feature works at all times and is independent of the state of CCR.2.

TRANSMIT SIDE OVERVIEW

The transmit side of the DS2180A is made up of six major functional blocks: timing and clock generation, data selector, bipolar coder, yellow alarm, F-bit data and CRC. The timing and clock generation circuit develops all onboard and output clocks to the system from inputs TCLK, TFSYNC, and TMSYNC. The yellow alarm circuitry generates mode-dependent yellow alarms. The CRC block generates checksum results utilized in 193E framing. F-bit data provides mode-dependent framing patterns and allows insertion of link or S-bit data externally. All of these blocks feed into the data selector where, under control of the CCR, TCR, TIRs and TTRs, the contents of the outgoing data stream are established by bit selection and insertion. The bipolar coder formats the output of the data selector to make it compatible with bipolar transmission techniques and inserts zero suppression codes. The bipolar coder also supports the onboard loopback feature. Input-to-output delay of the transmitter is 10 TCLK cycles.

RECEIVE SIDE OVERVIEW

Synchronizer

The heart of the receiver is the synchronizer monitor. This circuit serves two purposes: 1) monitoring the incoming data stream for loss of frame or multiframe alignment, and 2) searching for new frame alignment pattern when sync loss is detected. When sync loss is detected, the synchronizer begins an off-line search for the new alignment; all output timing signals remain at the old alignment with the exception of RSIGFR which is forced low during resync. When one and only one candidate is qualified, the output timing will move to the new alignment at the beginning of the next multiframe. One frame later, RLOS will transition low, indicating valid sync and the resumption of the normal sync monitoring mode. Several bits in the RCR allow tailoring of the resync algorithm by the user. These bits are described below.

Sync Time (RCR.2)

Bit RCR.2 determines the number of consecutive framing pattern bits to be qualified before SYNC is declared. If RCR.2=1, the algorithm will validate 24 bits; if RCR.2=0, 10 bits are validated. 24-bit testing results in superior false framing protection, while 10-bit testing minimizes reframe time (although in either case, the synchronizer will only establish resync when one and only one candidate is found).

Resync (RCR.0)

A zero-to-one transition of RCR.0 causes the synchronizer to search for the framing pattern sequence immediately, regardless of the internal sync status. In order to initiate another resync command, this bit must be cleared and then set again.

Sync Enable (RCR.1)

When RCR.1 is cleared, the receiver will initiate automatic resync if any of the following events occur: 1) an OOF event ("out-of-frame"), or 2) carrier loss (32 consecutive 0's appear at RPOS and RNEG). An OOF event occurs any time that 2 of 4 F_T or F_S bits are in error. When RCR.1 is set, the automatic resync circuitry is disabled; in this case, resync can only be initiated by setting RCR.0 to 1 or externally via a low-high transition on \overline{RST} . Note that using \overline{RST} to initiate resync resets the receive output timing while \overline{RST} is low; use of RCR.1 does not affect output timing until the new alignment is located.

Sync Criteria (RCR.3)

193E

Bit RCR.3 determines which sync algorithm is utilized when resync is in progress (RLOS=1). In 193E framing, when RCR.3=0, the synchronizer will lock only to the FPS pattern and will move to the new frame and multiframe alignment after the move to the new alignment. When RCR.3=1, the new alignment is further tested by a CRC code match. RLOS will transition low after a CRC match occurs. If no CRC match occurs in three attempts (three multiframes), the algorithm will reset and a new search for the framing pattern begins. It takes 9 ms for the synchronizer to check the first CRC code after the new alignment has been loaded. Each additional CRC test takes 3 ms. Regardless of the state of RCR.3, if more than one candidate exists after about 24 ms, the synchronizer will begin eliminating emulators by testing their CRC codes online in order to find the true framing candidate.

193S

In 193S framing, when RCR.3=1, the synchronizer will cross check the F_T pattern with the F_S pattern to help eliminate false framing candidates such as digital milliwatts. The F_S patterns are compared to the repeating pattern ...00111000111000...(00111X0 if CCR.3-YELMD—is equal to a 1). In this mode, F_T and F_S patterns must be correctly identified by the synchro-

nizer before sync is declared. Clearing RCR.3 causes the synchronizer to search for F_T patterns (101010...) without cross-coupling the F_S pattern. Frame sync will be established using the F_T information, while multiframe sync will be established only if valid F_S information is present. If no valid F_S pattern is identified, the synchronizer will move to the F_T alignment, RLOS will go

low, and a false multiframe position may be indicated by RMSYNC. RFER will indicate when the received S-bit pattern does not match the assumed internal multiframe alignment. This mode will be used in applications where non-standard S-bit patterns exist. In such applications, multiframe alignment information can be decoded externally by using the S-bits present at RLINK.

AVERAGE REFRAME TIME¹ Table 9

FRAME MODE	RCR.2=0			RCR.2=1			UNITS
	MIN	AVG	MAX	MIN	AVG	MAX	
193S	3.0	3.75	4.5	6.5	7.25	8.0	ms
193E	6.0	7.5	9.0	13.0	14.5	16.0	

NOTE:

1. Average Reframe Time is defined here as the average time it takes from the start of sync (rising edge of RLOS) to the actual loading of the new alignment (on a multiframe edge) into the output receive timing.

BACKPLANE INTERFACE USING DS2180A AND DS2176 Figure 22

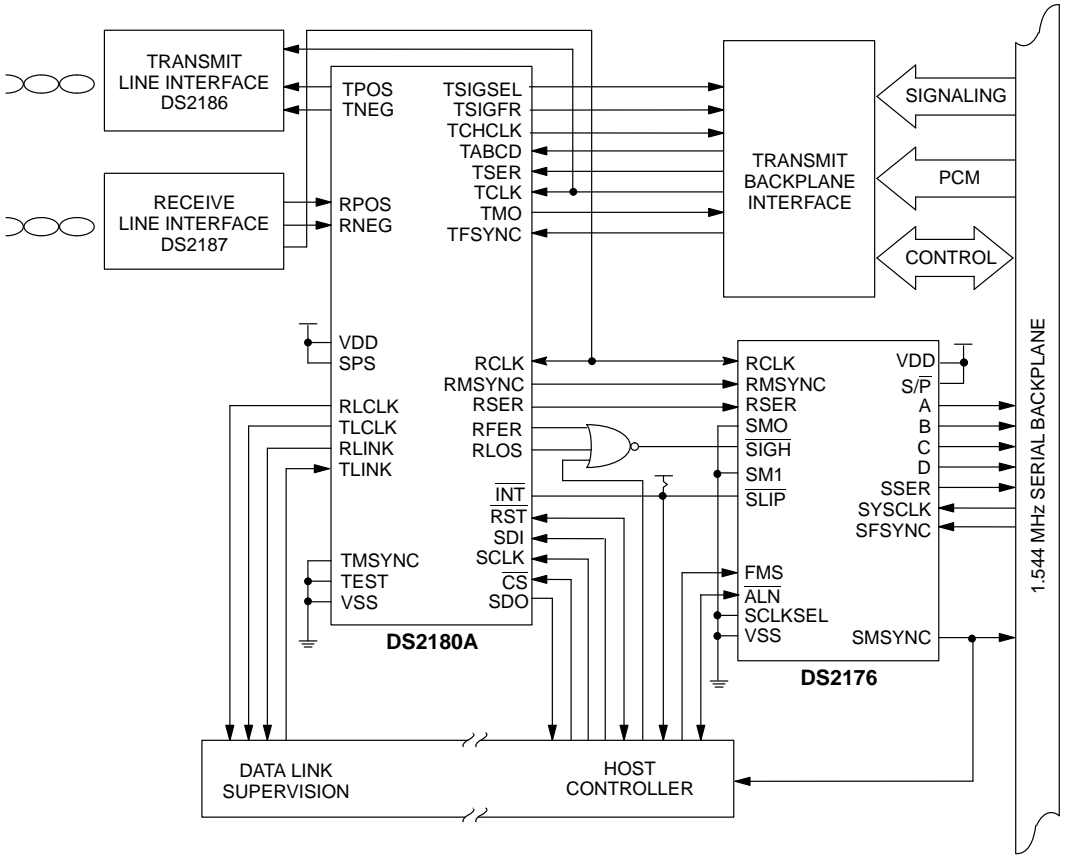

PROCESSOR-BASED TRANSMIT SIGNALING INSERTION Figure 23

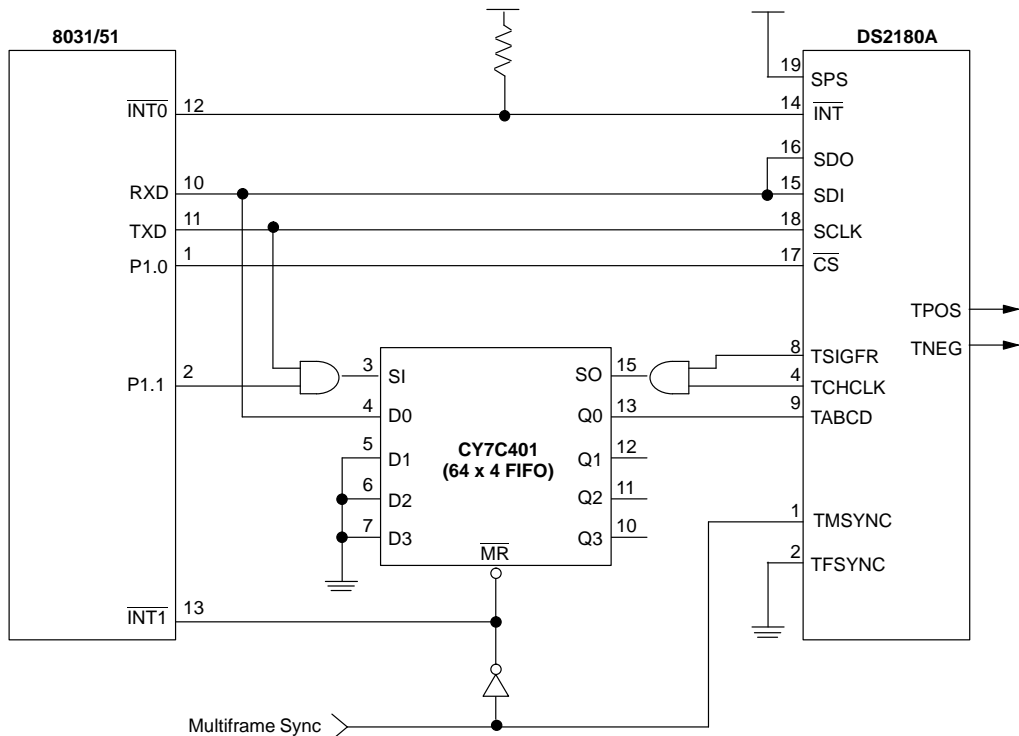

PROCESSOR-BASED SIGNALING

Many robbed-bit signaling applications utilize a micro-processor to insert transmit signaling data into the outgoing data stream. The circuit shown in Figure 23 “decouples” the processor timing from that of the DS2180A by use of a small FIFO memory. The processor writes to the FIFO (six bytes are written: three for A data, three for

B data) only when signaling updates are required. The system is interrupt-driven from the transmit multiframe sync input; the processor must update the FIFO prior to Frame 6 (625 μs after interrupt) to prevent data corruption. The application circuit shown supports 193S framing. Additional hardware is required for 193E applications.

ABSOLUTE MAXIMUM RATINGS*

Voltage on Any Pin Relative to Ground	-1.0V to 7.0V
Operating Temperature	0°C to +70°C
Storage Temperature	-55°C to 125°C
Soldering Temperature	260°C for 10 seconds

* This is a stress rating only and functional operation of the device at these or any other conditions above those indicated in the operation sections of this specification is not implied. Exposure to absolute maximum rating conditions for extended periods of time may affect reliability.

RECOMMENDED DC OPERATING CONDITIONS

(0°C to 70°C)

PARAMETER	SYMBOL	MIN	TYP	MAX	UNITS	NOTES
Logic 1	V_{IH}	2.0		$V_{DD} + .3$	V	
Logic 0	V_{IL}	-0.3		+0.8	V	
Supply	V_{DD}	4.5	5.0	5.5	V	

CAPACITANCE $(t_A = 25^\circ\text{C})$

PARAMETER	SYMBOL	MIN	TYP	MAX	UNITS	NOTES
Input Capacitance	C_{IN}			5	pF	
Output Capacitance	C_{OUT}			7	pF	

DC ELECTRICAL CHARACTERISTICS $(0^\circ\text{C to } 70^\circ\text{C}; V_{DD} = 5V \pm 10\%)$

PARAMETER	SYMBOL	MIN	TYP	MAX	UNITS	NOTES
Supply Current	I_{DD}		3	10	mA	1,2
Input Leakage	I_{IL}			1	μA	
Output Leakage	I_{LO}			1	μA	3
Output Current @ 2.4V	I_{OH}	-1			mA	4
Output Current @ .4V	I_{OL}	+4			mA	5

NOTES:

1. TCLK = RCLK = 1.544 MHz.
2. Outputs open.
3. Applies to SDO when tri-stated.
4. All outputs except $\overline{\text{INT}}$, which is open collector.
5. All outputs.

AC ELECTRICAL CHARACTERISTICS

(0°C to 70°C; $V_{DD} = 5V \pm 10\%$)

PARAMETER	SYMBOL	MIN	TYP	MAX	UNITS	NOTES
SDI to SCLK Setup	t_{DC}	50			ns	
SCLK to SDI Hold	t_{CDH}	50			ns	
SDI to SCLK Falling Edge	t_{CD}	50			ns	
SCLK Low Time	t_{CL}	250			ns	
SCLK High Time	t_{CH}	250			ns	
SCLK Rise & Fall Time	t_R, t_F			500	ns	
\overline{CS} to SCLK Setup	t_{CC}	50			ns	
SCLK to \overline{CS} Hold	t_{CCH}	50			ns	
\overline{CS} Inactive Time	t_{CWH}	250			ns	
SCLK to SDO Valid ²	t_{CDV}			200	ns	
\overline{CS} to SDO High Z	t_{CDZ}			75	ns	
SCLK Setup to \overline{CS} Falling	t_{SCC}	50			ns	

NOTES:

1. Measured at $V_{IH}=2.0\text{ V}$; $V_{IL}=0.8\text{ V}$ and 10 ns maximum rise and fall time.
2. Output load capacitance = 100 pF.

SERIAL PORT WRITE AC TIMING DIAGRAM

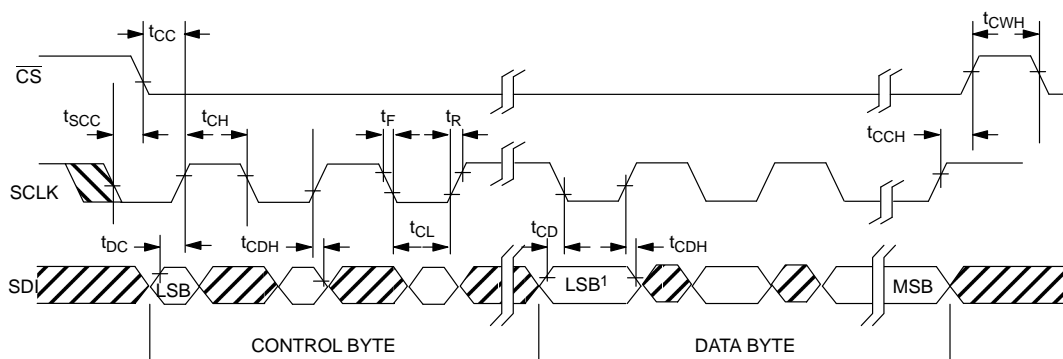

NOTES:

1. Data byte bits must be valid across low clock periods to prevent transients in operating modes.
2. Shaded regions indicate "don't care" states of input data.

SERIAL PORT READ AC TIMING

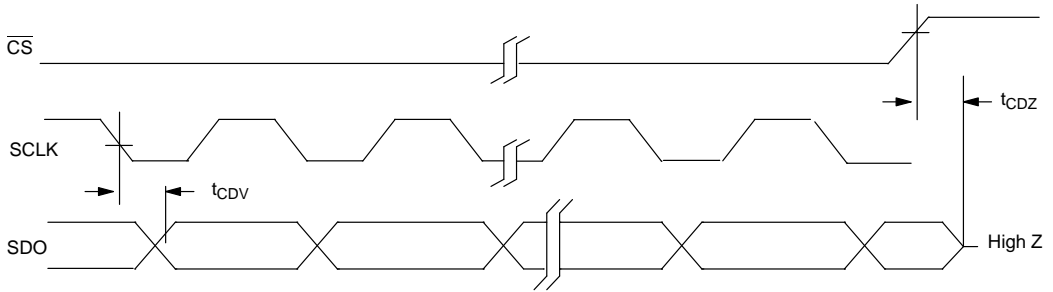

NOTE:

1. Serial port write must precede a port read to provide address information.

AC ELECTRICAL CHARACTERISTICS¹ – TRANSMIT(0°C to 70°C; $V_{DD} = 5V \pm 10\%$)

PARAMETER	SYMBOL	MIN	TYP	MAX	UNITS	NOTES
TCLK Period	t_p	250	648		ns	
TCLK Pulse Width	t_{WL}, t_{WH}	125	324		ns	
TCLK, RCLK Rise & Fall Times	t_F, t_R		20		ns	
TSER, TABCD, TLINK Setup to TCLK Falling	t_{STD}	50			ns	
TSER, TABCD, TLINK Hold from TCLK Falling	t_{HTD}	50			ns	
TFSYNC, TMSYNC Setup to TCLK Rising	t_{STS}	-125		125	ns	
Propagation Delay TFSYNC to TMO, TSIGSEL, TSIGFR, TLCLK	t_{PTS}			75	ns	
Propagation Delay TCLK to TCHCLK	t_{PTCH}			75	ns	
TFSYNC, TMSYNC Pulse Width	t_{TSP}	100			ns	

NOTES:

1. Measured at $V_{IH} = 2.0V$; $V_{IL} = .8V$ and 10 ns maximum rise and fall time.
2. Output load capacitance = 100 pF.

AC ELECTRICAL CHARACTERISTICS¹ – RECEIVE(0°C to 70°C; $V_{DD} = 5V \pm 10\%$)

PARAMETER	SYMBOL	MIN	TYP	MAX	UNITS	NOTES
Propagation Delay RCLK to RMSYNC, RFSYNC, RSIGSEL, RSIGFR, RLCLK, RCHCLK	t_{PRS}			75	ns	
Propagation Delay RCLK to RSER, RABCD, RLINK	t_{PRD}			75	ns	
Transition Time All Outputs	t_{TTR}			20	ns	
RCLK Period	t_P	250	648		ns	
RCLK Pulse Width	t_{WL}, t_{WH}	125	324		ns	
RCLK Rise & Fall Times	t_R, t_F		20		ns	
RPOS, RNEG Setup to RCLK Falling	t_{SRD}	50			ns	
RPOS, RNEG Hold to RCLK Falling	t_{HRD}	50			ns	
Propagation Delay RCLK to RYEL, RCL, RFER, RLOS, RBV	t_{PRA}			75	ns	
Minimum \overline{RST} Pulse Width on System Power Up or Restart	t_{RST}	1			μs	

NOTES:

1. Measured at $V_{IH} = 2.0V$; $V_{IL} = .8V$ and 10 ns maximum rise and fall times.
2. Output load capacitance = 100 pF.

TRANSMIT AC TIMING DIAGRAM

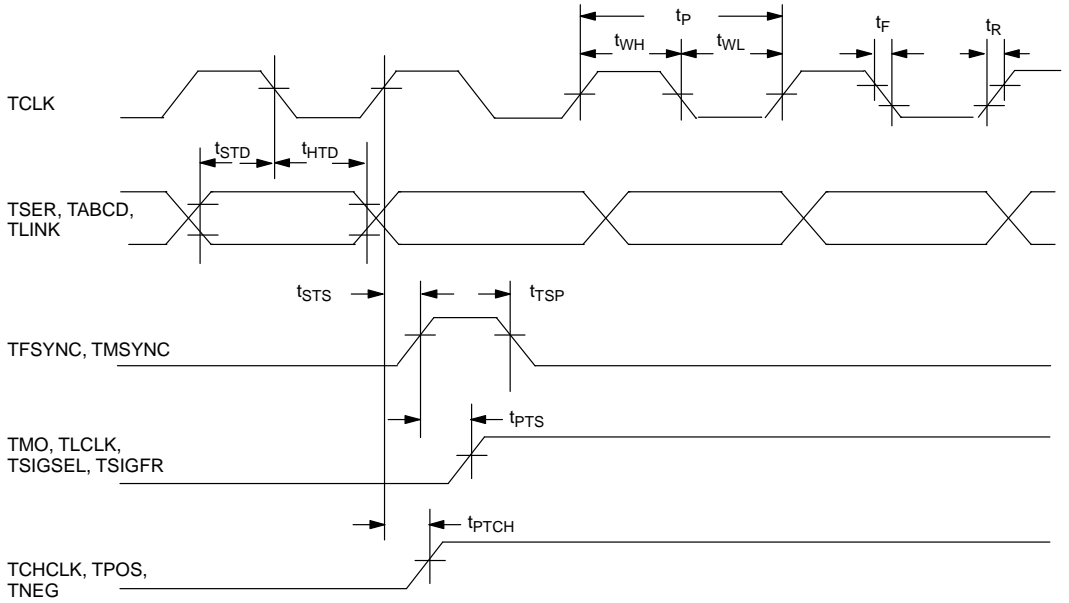

RECEIVE AC TIMING DIAGRAM

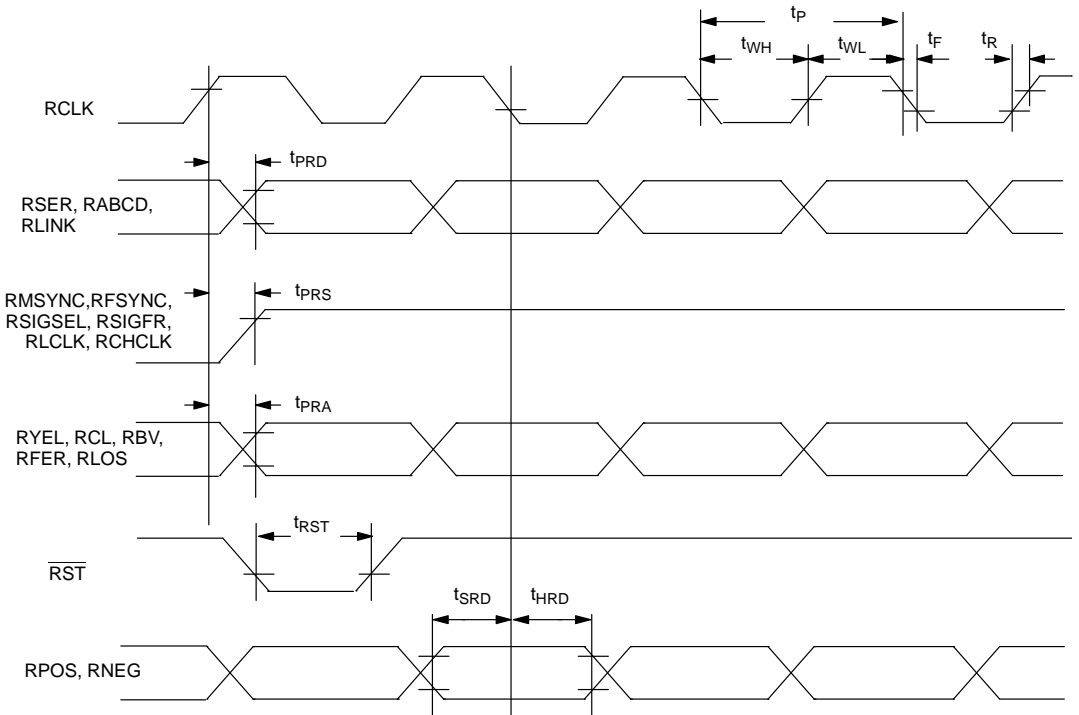

DS2180A SERIAL T1 TRANSCEIVER (600 MIL DIP)

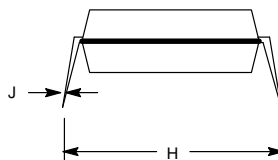
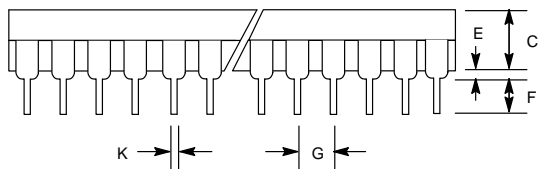
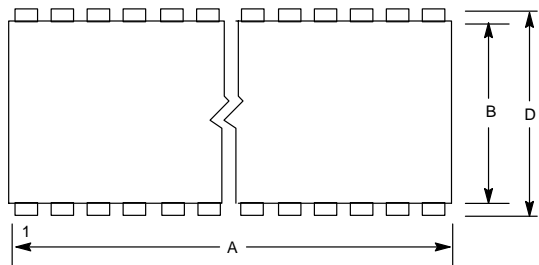

DIM.	INCHES	
	MIN.	MAX.
A	2.050	2.075
B	0.530	0.550
C	0.140	0.160
D	0.600	0.625
E	0.015	0.040
F	0.120	0.145
G	0.090	0.110
H	0.625	0.675
J	0.008	0.012
K	0.015	0.022

DS2180AQ SERIAL T1 TRANSCEIVER (PLCC)

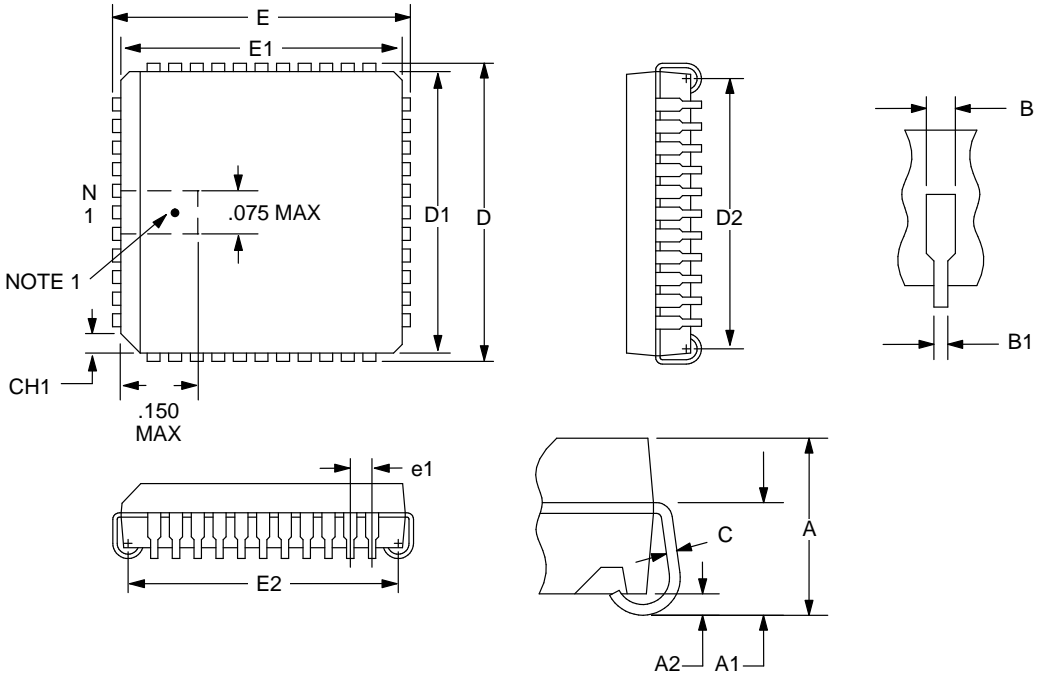

NOTE1: PIN 1 IDENTIFIER TO BE LOCATED IN ZONE INDICATED.

DIM.	INCHES	
	MIN.	MAX.
A	0.165	0.180
A1	0.090	0.120
A2	0.020	—
B	0.026	0.033
B1	0.013	0.021
C	0.009	0.012
CH1	0.042	0.048
D	0.685	0.695
D1	0.650	0.656
D2	0.590	0.630
E	0.685	0.695
E1	0.650	0.656
E2	0.590	0.630
e1	0.050 BSC	
N	44	—