

DS3161,2,3,4 Multi-Port ATM/Packet PHYs For DS3/E3

FEATURES

- Universal PHYs map ATM cells and/or HDLC packets into DS3 or E3 data streams
- Single, dual, triple and quad-port devices
- UTOPIA 2 or 3 or POS-PHY 2 or 3 interface with 8, 16, or 32 bit bus width up to 66 MHz
- Ports independently configurable for cell or packet traffic in POS-PHY bus modes
- Direct, PLCP and clear-channel cell mapping
- Direct and clear-channel packet mapping
- On-chip DS3 (M23 or C-bit) and E3 (G.751 or G.832) framers
- Ports independently configurable for DS3, E3 or arbitrary framing protocol up to 52 Mbps
- Programmable (externally controlled or internally hardware based engine) subrate DS3/E3 circuitry
- DS3/E3/PLCP alarm generation and detection
- Built-in HDLC controllers with 256 byte FIFOs for DS3 PMDL, G.751 Sn bit or G.832 NR/GC bytes
- On-chip BERTs for PRBS and repetitive pattern generation, detection and analysis
- Full featured DS3/E3/PLCP alarms
- Large performance-monitoring counters for accumulation intervals up to 1 second
- Flexible overhead insertion/extraction ports for DS3, E3 and PLCP framers
- Loopbacks include line, diagnostic, framer payload and system interface
- Ports can be disabled to reduce power
- Integrates clock rate adapter to generate the required 44.736 MHz for DS3, 34.368 MHz for E3, and/or 52 MHz for arbitrary framing protocol up to 52 Mbps
- 8/16-bit generic microprocessor interface
- 3.3V supply with 5V tolerant I/O
- Small high-density Thermally Enhanced (TE) Chip Scale BGA packaging
- IEEE 1149.1 JTAG test port

www.maxim-ic.com/telecom

Note: This Product Preview contains preliminary information and is subject to change without notice. Some revisions of this device may incorporate deviations from published specifications known as errata. Multiple revisions of any device may be simultaneously available through various sales channels. For information about device errata, visit: <http://dbserv.maxim-ic.com/errata.cfm>.

DS3161,2,3,4 Multi-Port ATM/Packet PHYs For DS3/E3

FUNCTIONAL DIAGRAM

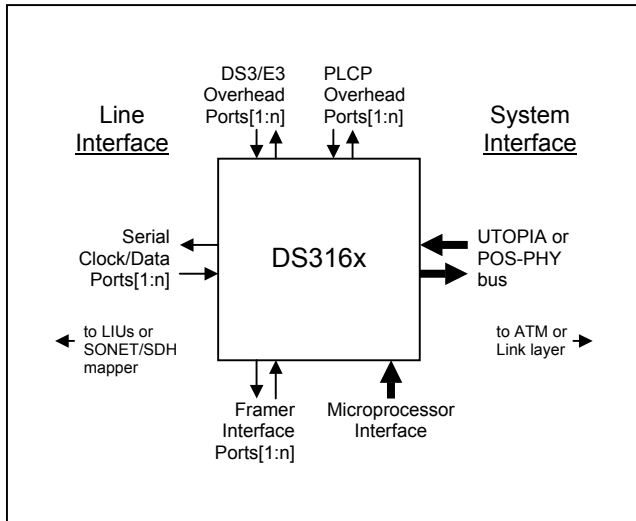

ORDERING INFORMATION

Commercial Temperature Range (0°C to 70°C)

DS3161	Single	400-lead TE-CSBGA
DS3162	Dual	400-lead TE-CSBGA
DS3163	Triple	400-lead TE-CSBGA
DS3164	Quad	400-lead TE-CSBGA

Industrial Temperature Range (-40°C to 85°C)

DS3161N	Single	400-lead TE-CSBGA
DS3162N	Dual	400-lead TE-CSBGA
DS3163N	Triple	400-lead TE-CSBGA
DS3164N	Quad	400-lead TE-CSBGA

www.maxim-ic.com/telecom

Note: This Product Preview contains preliminary information and is subject to change without notice. Some revisions of this device may incorporate deviations from published specifications known as errata. Multiple revisions of any device may be simultaneously available through various sales channels. For information about device errata, visit: <http://dbserv.maxim-ic.com/errata.cfm>.

DESCRIPTION

The DS316x Multi-port PHYs map ATM cells and/or packets into as many as four DS3/E3 data streams. Dedicated cell processor and packet processor blocks prepare outgoing cells or packets for transmission and check incoming cells or packets upon arrival. Built-in DS3/E3 framers transmit and receive cell/packet data in properly formatted M23 DS3, C-bit DS3, G.751 E3 or G.832 E3 data streams. PLCP framers provide legacy ATM transmission-convergence support. With integrated hardware support for both cells and packets, the DS316x PHYs enable high-density universal line cards for unchanneled DS3/E3.

1 BLOCK DIAGRAM

Figure 1–1 Block Diagram

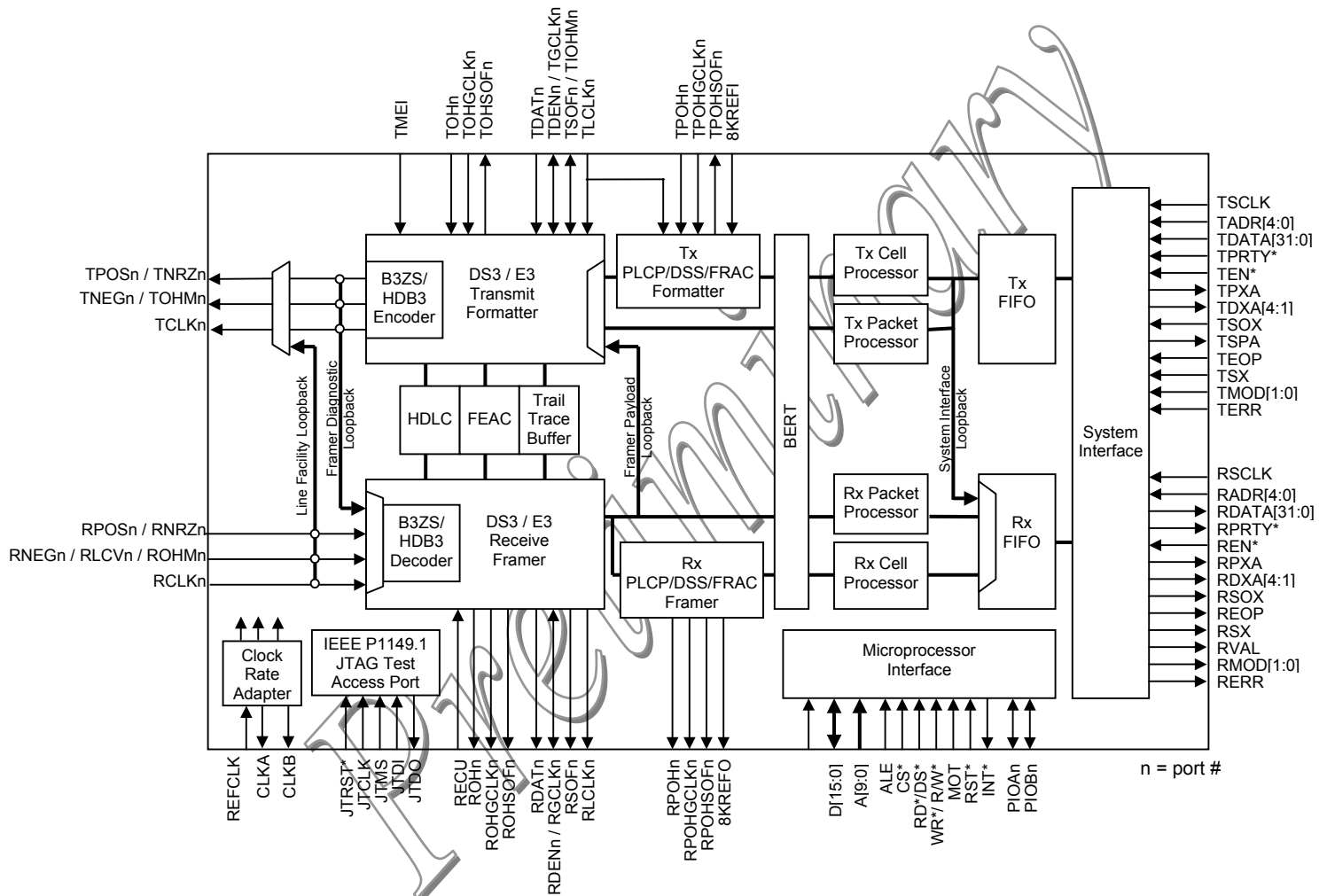

2 APPLICATIONS

- Access Concentrators
- Multi-Service Access Platforms
- ATM and Frame Relay Equipment
- Routers and Switches
- SONET/SDH ADM
- Digital Cross Connect
- PDH Multiplexer/Demultiplexer

Figure 2-1 Four-Port Unchannelized ATM over T3/E3 Card

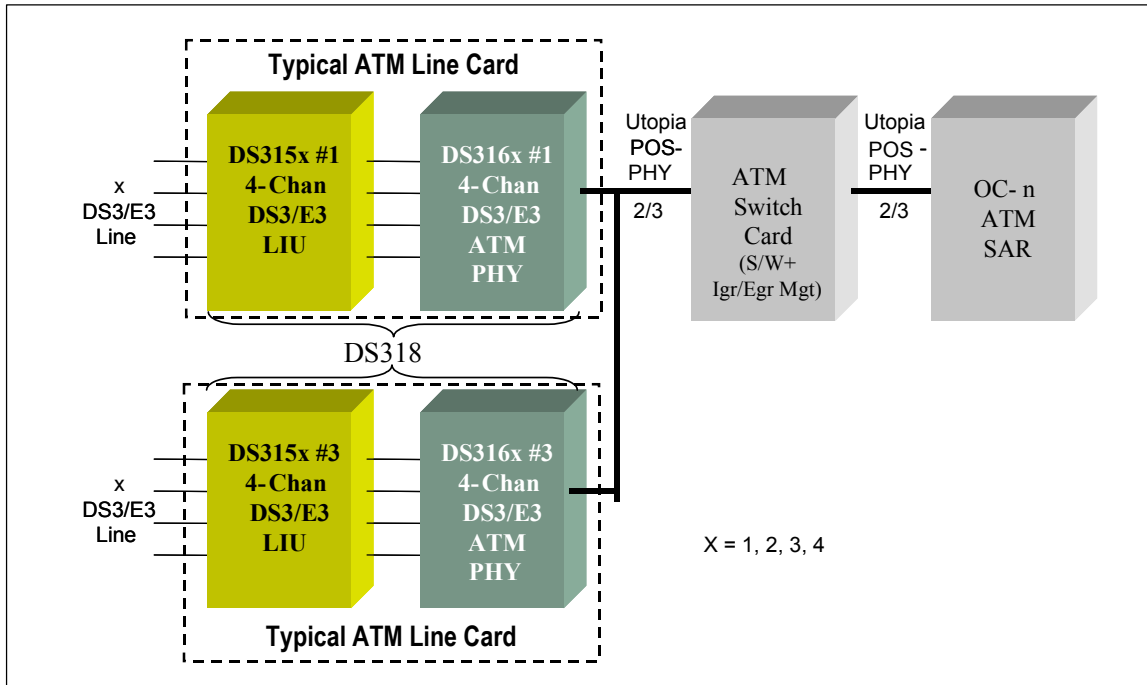
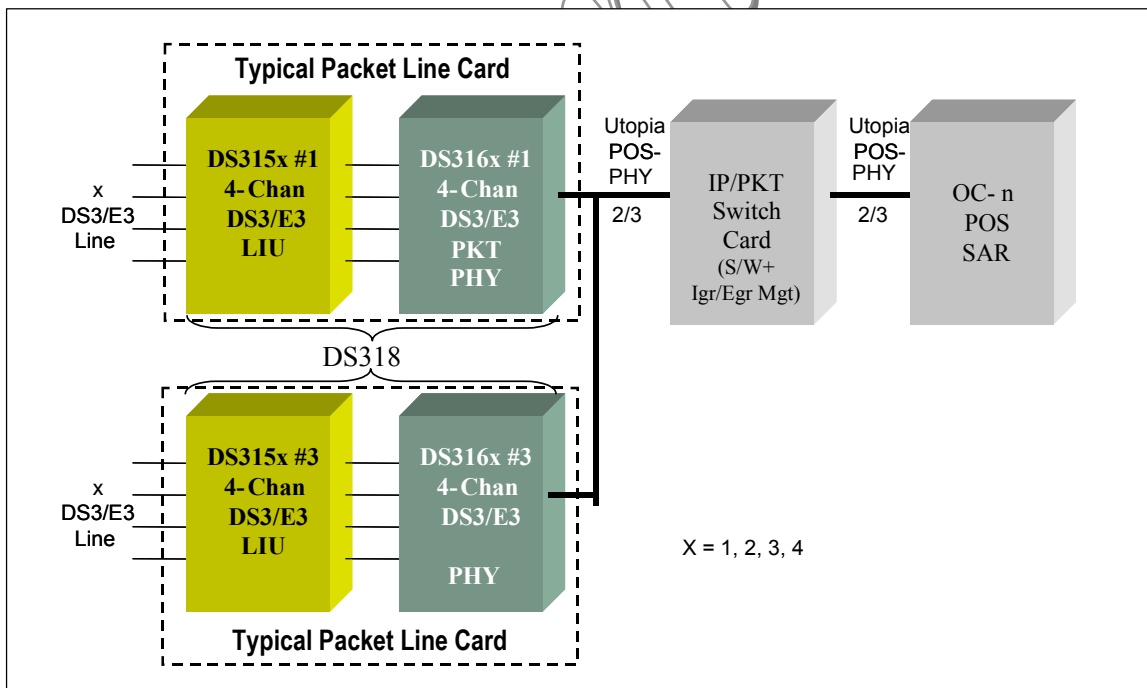

Figure 2-2 Four-Port Unchannelized HDLC over T3/E3 Line Card



3 FEATURE DETAILS

3.1 Global Features

- System interface configurable for UTOPIA 2 / UTOPIA 3 for ATM cell traffic or POS-PHY 2 / POS-PHY 3 for HDLC or mixed packet/cell traffic
- Supports the following transmission protocols:
 - Direct-mapped ATM over DS3 or subrate DS3
 - PLCP-mapped ATM over DS3
 - Direct-mapped ATM over G.751 E3 or subrate G.751 E3
 - PLCP-mapped ATM over G.751 E3
 - Direct-mapped ATM over G.832 E3 or subrate G.832 E3
 - Direct-mapped ATM over externally-defined frame formats up to 52 Mbps
 - Clear-channel ATM (cell-based physical layer) line rates up to 52 Mbps
 - Direct-mapped HDLC over DS3 or subrate DS3
 - Direct-mapped HDLC over G.751 E3 or subrate G.751 E3
 - Direct-mapped HDLC over G.832 E3 or subrate G.832 E3
 - Direct-mapped HDLC over externally-defined frame formats up to 52 Mbps
 - Clear-channel HDLC at any line rate up to 52 Mbps
- In UTOPIA bus mode, ports are independently configurable for any ATM protocol
- In POS-PHY bus mode, ports are independently configurable for any ATM or HDLC protocol
- Provides all necessary I/O to support externally controlled subrate DS3 or E3 on any ports
- LIU interface can be AMI logic (POS/NEG/CLK) or binary (DAT/CLK/LCV)
- Supports gapped 52 MHz clock rates for signals embedded in SONET/SDH
- Clock, data and control signals can be inverted to allow a glueless interface to other devices
- Programmable I/O pins (two per port) can be used to control neighboring LIUs (DS3/E3 setting, LBO setting, etc.)
- Detection of loss of transmit clock and loss of receive clock
- Manual or automatic one-second update of performance monitoring counters
- Each port can be put into a low-power standby mode when not being used

3.2 Receive DS3/E3 Framer Features

- Frame synchronization for M23 or C-bit Parity DS3, G.751 E3 or G.832 E3
- B3ZS/HDB3 decoding
- Detection and accumulation of bipolar violations (BPV), code violations (CV), excessive zeroes occurrences (EXZ), F-bit errors, M-bit errors, FAS errors, LOF occurrences, P-bit parity errors, CP-bit parity errors, BIP-8 errors, and far end block errors (FEBE)
- Detection of RDI, AIS, DS3 idle signal, loss of signal (LOS), severely error framing event (SEFE), change of frame alignment (COFA), receipt of B3ZS/HDB3 codewords, DS3 application ID bit, DS3 M23/C-bit format mismatch, G.751 national bit, and G.832 RDI (FERF), payload type, and timing marker bits
- HDLC controller with 256 byte FIFO for DS3 path maintenance data link (PMDL), G.751 national bit or G.832 NR/GC channels
- FEAC controller with four-codeword FIFO for DS3 FEAC channel
- 16-byte Trail Trace Buffer compares and stores G.832 trail access point identifier
- C bits configurable as payload or overhead
- Most framing overhead fields presented on the receive overhead port

- Framer pass-through mode for clear channel applications and externally defined frame formats
- Built-in support for subrate DS3/E3

3.3 Receive PLCP Framing Features

- PLCP frame synchronization
- C1 cycle/stuff counter interpretation
- Detection of out of frame (OOF), BIP-8 errors, FEBE and RAI (Yellow Signal)
- Frame timing is presented on the 8KREFO output pin
- All path overhead fields presented on the PLCP receive overhead port

3.4 Receive Cell Processor Features

- HEC-based cell delineation within the DS3/E3 frame, the PLCP frame, an externally defined frame, or the entire line bandwidth
- Cell descrambling using the self-synchronizing scrambler ($x^{43}+1$) for ATM over DS3/E3 or the distributed sample scrambler for clear-channel ATM (cell-based physical layer)
- HEC error detection and correction; HEC discard
- Filtering of idle, unassigned and/or invalid cells (provisionable)
- Header pattern comparison vs. 32-bit header pattern and mask registers; counting of matching or non-matching cells; discard of matching or non-matching cells
- Four-cell Receive FIFO
- Controls include enables/disables/settings for: cell processing, coset polynomial addition, error correction, erred cell extraction, cell descrambling, idle/unassigned/invalid cell filtering, header pattern match counting/discarding, LCD integration time
- Status fields include: out of cell delineation (OCD), loss of cell delineation (LCD) and receipt of idle, unassigned, invalid, erred, corrected or header-pattern-match cells
- Performance monitoring counters for forwarded cells, corrected cells, uncorrectable cells, header pattern match/no-match cells, and filtered idle/unassigned/invalid cells

3.5 Receive Packet Processor Features

- Packet descrambling using the self-synchronizing scrambler ($x^{43}+1$)
- Flag detection, packet delineation, and interframe fill discard (flags and all-ones)
- Packet abort detection and accumulation
- Bit or octet destuffing
- FCS checking (16-bit or 32-bit), error accumulation, and FCS discard
- Packet size checking vs. programmable minimum and maximum size registers
- Abort declaration for packets with non-integral number of bytes
- Controls include enables/disables/settings for: packet processing, descrambling, 16/32-bit FCS, filtering of FCS erred packets, FCS discard, minimum/maximum packet size
- Status fields include: receipt of FCS erred packet, aborted packet, size violation packet, non-integer-length packets
- Performance monitoring counters for forwarded packets, forwarded bytes, aborted bytes, FCS erred packets, aborted packets, size violation packets (min, max, non-integer-length)

3.6 Receive FIFO Features

- Storage capacity for four cells or 256 bytes of packet data
- Programmable port address

- Programmable fill level thresholds
- Underflow and overflow status indications

3.7 Receive System Interface Features

- UTOPIA 2 / UTOPIA 3 interface in cell mode, POS-PHY 2 / POS-PHY 3 interface in packet or mixed traffic modes
- 8, 16, or 32 bit data bus at clock rates from 10 MHz to 66 MHz
- Polled and direct cell available outputs
- Controls include enables/disables/settings for: HEC transfer, signal inversions, parity enable/polarity, cell available desertion time

3.8 Transmit System Interface Features

- UTOPIA 2 / UTOPIA 3 interface in cell mode, POS-PHY 2 / POS-PHY 3 interface in packet or mixed traffic modes
- 8, 16, or 32 bit data bus at clock rates from 10 MHz to 66 MHz
- Polled and direct cell available outputs
- Controls include enables/disables/settings for: HEC transfer, signal inversions, parity enable/polarity, cell available desertion time

3.9 Transmit FIFO Features

- Storage capacity for four cells or 256 bytes of packet data
- Programmable port address
- Programmable fill level thresholds
- Underflow and overflow status indications

3.10 Transmit Cell Processor Features

- Programmable fill cell type
- HEC calculation and insertion/overwrite, including coset addition
- Cell scrambling using the self-synchronizing scrambler ($x^{43}+1$) for ATM over DS3/E3 or the distributed sample scrambler for clear-channel ATM (cell-based physical layer)
- Single-bit and multiple-bit header error insertion for diagnostics
- Controls include enables/disables/settings for: cell processing, HEC insertion, coset polynomial addition, cell scrambling, fill cell type, error insertion type/rate/count, HEC bit corruption
- Counter for number of cells read from the transmit FIFO
- Cell mapping into the DS3/E3 frame, the PLCP frame, an externally defined frame, or the entire line bandwidth

3.11 Transmit Packet Processor Features

- FCS calculation (16-bit or 32-bit) and insertion/overwrite
- Programmable FCS error insertion for diagnostics
- Bit or octet stuffing
- Programmable inter-frame fill insertion (flags or all-ones)
- Automatic packet abort insertion
- Packet scrambling using the self-synchronizing scrambler ($x^{43}+1$)
- Controls include enables/disables/settings for: packet processing, FCS insertion or overwrite, 16/32-bit FCS, inter-frame fill type/length, scrambling, FCS error insertion type/rate/count

- Counters for number of packets and bytes read from the transmit FIFO

3.12 Transmit PLCP Formatter Features

- Insertion of FAS bytes (A1, A2), path overhead identification (POI) bytes, and path overhead bytes
- Generation of BIP-8 (B1), FEBE and RAI (G1)
- C1 cycle/stuff counter generation referenced to the 8KREFI input pin, referenced to the received PLCP timing, or based on a fixed stuff pattern
- Automatic or manual insertion of FAS errors, BIP-8 errors
- All path overhead fields can be sourced from the PLCP transmit overhead port

3.13 Transmit DS3/E3 Formatter Features

- Insertion of framing overhead for M23 or C-bit parity DS3, G.751 E3 or G.832 E3
- B3ZS/HDB3 encoding
- Generation of RDI, AIS, DS3 idle signal, and G.832-E3 RDI
- Automatic or manual insertion of bipolar violations (BPVs), excessive zeroes (EXZ) occurrences, F-bit errors, M-bit errors, FAS errors, P-bit parity errors, CP-bit parity errors, BIP-8 errors, and far end block errors (FEBE)
- HDLC controller with 256 byte FIFO for DS3 path maintenance data link (PMDL), G.751 national bit or G.832 NR or GC channels
- FEAC controller for DS3 FEAC channel can be configured to send one codeword, one codeword continuously, or two different codewords back-to-back to send DS3 Line Loopback commands
- 16-byte Trail Trace Buffer sources the G.832 trail access point identifier
- Insertion of G.832 payload type and timing marker bits from registers
- C bits configurable as payload or overhead; as overhead they can be controlled from registers or the transmit overhead port
- Most framing overhead fields can be sourced from transmit overhead port
- Formatter pass-through mode for clear channel applications and externally defined frame formats
- Built-in support for subrate DS3/E3

3.14 HDLC Controller Features

- 256-byte receive and transmit FIFOs
- Handles all of the normal Layer 2 tasks including zero stuffing/destuffing, FCS generation/checking, abort generation/checking, flag generation/detection, and byte alignment
- Programmable high or low water marks for the transmit and receive FIFOs
- Terminates the Path Maintenance Data Link in DS3 C-bit Parity mode or the G.751 Sn bit or the G.832 NR or GC channels

3.15 FEAC Controller Features

- Designed to handle multiple FEAC codewords without Host intervention
- Receive FEAC automatically validates incoming codewords and stores them in a 4-codeword FIFO
- Transmit FEAC can be configured to send one codeword, one codeword continuously, or two different codewords back-to-back to send DS3 Line Loopback commands
- Terminates the FEAC channel in DS3 C-Bit Parity mode or the Sn bit in E3 mode

3.16 Trail Trace Buffer Features

- Extraction and storage of the incoming G.832 trail access point identifier in a 16-byte receive register

- Insertion of the outgoing trail access point identifier from a 16-byte transmit register
- Receive trace identifier unstable status indication

3.17 Bit Error Rate Tester (BERT) Features

- Generates and detects pseudo-random patterns and repetitive patterns from 1 to 32 bits in length
- Supports pattern insertion/extraction in PLCP payload, DS3/E3 payload, or entire data stream
- Large 24-bit error counter allows testing to proceed for long periods without host intervention
- Errors can be inserted in the generated BERT patterns for diagnostic purposes (single bit errors or specific bit-error rates)

3.18 Loopback Features

- Line facility loopback (receive to transmit) with optionally transmitting unframed all-one payload toward system/trunk interface
- Framer diagnostic loopback (transmit to receive) with optionally transmitting unframed all-one signal toward line/tributary interface
- Simultaneous line facility loopback and framer diagnostic loopback
- Framer payload loopback (receive to transmit) with optionally transmitting unframed all-one payload toward system/trunk interface
- System interface loopback (transmit to receive)

3.19 Microprocessor Interface Features

- Multiplexed or non-multiplexed 8 or 16-bit control port
- Intel and Motorola bus compatible
- Global reset input pin
- Global interrupt output pin
- Two programmable I/O pins per port

3.20 Subrate Features

- Independent per port built-in support for subrate DS3 or E3
- Independent subrate operation for both Rx and Tx data paths
- Subrate operation for each channel is totally independent from the other channels' operation, i.e. all subrate functions within the device are mutually exclusive
- Three distinct subrate algorithms:
 - (FFRAC) Externally controlled with DS3 or E3 payload manipulating capability
 - (XFRAC) Externally controlled with simple DS3 or E3 data rate reduction capability
 - (IFRAC) Internally controlled with flexible DS3 or E3 data rate reduction capability
- Subrate algorithm selection is on per port basis
- Internal subrate mechanism allows down to bit-level granularity of the DS3 or E3 payload

4 STANDARDS COMPLIANCE

Specification	Specification Title
ANSI	
T1.107-1995	<i>Digital Hierarchy – Formats Specifications</i>
T1.231-1997	<i>Digital Hierarchy – Layer 1 In-Service Digital Transmission Performance Monitoring</i>

Specification	Specification Title
T1.404-1994	<i>Network-to-Customer Installation – DS3 Metallic Interface Specification</i>
T1.646-1995	<i>Broadband ISDN – Physical Layer Specification for User-Network Interfaces Including DSI/ATM</i>
ATM Forum	
af-phy-0034.000	<i>E3 Public UNI, August, 1995</i>
af-phy-0039.000	<i>UTOPIA Level 2, Version 1.0, June, 1995</i>
af-phy-0043.000	<i>A Cell-Based Transmission Convergence Sublayer for Clear Channel Interfaces, November, 1995</i>
af-phy-0054.000	<i>DS3 Physical Layer Interface Specification, January, 1996</i>
af-phy-0136.000	<i>UTOPIA 3 Physical Layer Interface, November, 1999</i>
af-phy-0143.000	<i>Frame-based ATM Interface (Level 3), March, 2000</i>
af-bici-0013.003	<i>BISDN Inter Carrier Interface (B-ICI) Specification Version 2.0 (Integrated), December, 1995</i>
ETSI	
ETS 300 337	<i>Transmission and Multiplexing (TM); Generic frame structures for the transport of various signals (including Asynchronous Transfer Mode (ATM) cells and Synchronous Digital Hierarchy (SDH) elements) at the ITU-T Recommendation G.702 hierarchical rates of 2 048 kbit/s, 34 368 kbit/s and 139 264 kbit/s, Second Edition, June, 1997</i>
ETS 300 689	<i>Business TeleCommunications (BTC); 34 Mbps digital leased lines (D34U and D34S), Terminal equipment interface, V 1.2.1, 2001-07</i>
IEEE	
IEEE Std 1149-1990	<i>IEEE Standard Test Access Port and Boundary-Scan Architecture, (Includes IEEE Std 1149-1993) October 21, 1993</i>
IETF	
RFC 1661	<i>The Point-to-Point Protocol (PPP), July, 1994</i>
RFC 1662	<i>PPP in HDLC-like Framing, July, 1994</i>
RFC 2496	<i>Definition of Managed Objects for the DS3/E3 Interface Type, January, 1999</i>
ISO	
ISO 3309:1993	<i>Information Technology – Telecommunications & information exchange between systems – High Level Data Link Control (HDLC) procedures – Frame structure, Fifth Edition, 1993</i>
ITU-T	
G.703	<i>Physical/Electrical Characteristics of Hierarchical Digital Interfaces, 1991</i>
G.704	<i>Synchronous Frame Structures Used at 1544, 6312, 2048, 8488 and 44 736 kbit/s Hierarchical Levels, July, 1995</i>
G.751	<i>Digital Multiplex Equipment Operating at the Third Order Bit Rate of 34,368 kbit/s and the Fourth Order bit Rate of 139,264 kbit/s and Using Positive Justification, 1993</i>
G.775	<i>Loss Of Signal (LOS) and Alarm Indication Signal (AIS) Defect Detection and Clearance Criteria, November, 1994</i>
G.804	<i>ATM Cell Mapping Into Plesiochronous Digital Hierarchy (PDH), November, 1993</i>
G.832	<i>Transport of SDH Elements on PDH Networks – Frame and Multiplexing Structures, November, 1995</i>
I.432	<i>B-ISDN User-Network Interface – Physical Layer Specification, March, 1993</i>

Specification	Specification Title
O.151	<i>Error Performance Measuring Equipment Operating at the Primary Rate and Above, October, 1992</i>
Q.921	<i>ISDN User-Network Interface – Data Link Layer Specification, March 1993</i>
OIF	
OIF-SPI3-01.0	<i>System Packet Interface Level 3 (SPI-3): OC-48 System Interface for Physical and Link Layer Devices</i>
Saturn® Group	
POS-PHY 2	<i>POS-PHY™ Level 2 Packet Over SONET Interface Specification for Physical Layer Devices, December, 1998</i>
POS-PHY 3	<i>POS-PHY Level 3 Packet Over SONET Interface Specification for Physical and Link Layer Devices, June, 2000</i>
Telcordia	
GR-499-CORE	<i>Transport Systems Generic Requirements (TSGR): Common Requirements, Issue 2, December 1998</i>
GR-820-CORE	<i>Generic Digital Transmission Surveillance, Issue 1, November 1994</i>

Saturn and POS-PHY are trademarks of PMC-Sierra, Inc.

Preliminary

5 PACKAGE MECHANICAL DIMENSIONS

The target package is a 27x27 mm 400-lead TE¹-CSBGA with ball pitch of 1.27mm for all port density configuration.

6 POWER ESTIMATE

Current typical power estimate is 2 Watts at 3.3V (pending mode of operation).

Preliminary

¹ TE-CSBGA = Thermally Enhanced Chip Scale Ball Grid Array
Rev 1.6