



## Video-Signal Conditioners with AGC and Back-Porch Clamp

### General Description

The MAX7450/MAX7451/MAX7452 complete front-end video-signal conditioners are designed to improve the quality of standard-definition video signals. The devices restore the DC level of the video input, correct for amplitude errors up to  $\pm 6\text{dB}$ , detect fault conditions, and filter out-of-band noise. The MAX7450/MAX7451/MAX7452 optimize the signal quality for further video processing through a crosspoint switch or video decoder (ADC). Each device integrates an input video clamp, automatic gain control (AGC), loss-of-sync (LOS) detector, and an out-of-band noise/lowpass filter. These devices also incorporate a user-selectable buffer gain (0 or  $+6\text{dB}$ ) and an AGC-disable function.

The MAX7450 and MAX7451 operate from dual power supplies of  $\pm 5\text{V}$  or  $\pm 3.3\text{V}$  respectively, and they restore the video blanking level to GND. The MAX7452 operates from a single  $+5\text{V}$  supply and features a user-adjustable clamp level.

The devices are available in an 8-pin SO package with an exposed pad and are specified for operation over the extended ( $-40^\circ\text{C}$  to  $+85^\circ\text{C}$ ) temperature range.

### Applications

Signal Conditioner for Standard-Definition Video Inputs

Security Video Systems

Video-Switching Systems

### Features

- ◆ Back-Porch Clamp to GND (MAX7450/MAX7451)
- ◆ Adjustable Back-Porch Clamp (MAX7452)
- ◆ Automatic Gain Control ( $\pm 6\text{dB}$  Range) Normalizes Signals to Standard Video Level
- ◆ Input Fault Detection with LOS Output
- ◆ Inherent 50Hz/60Hz Input Rejection of 60dB
- ◆ Single-Supply Operation: MAX7452 ( $+5\text{V}$ )
- ◆ Out-of-Band Noise Filter
- ◆ Output Buffer Drives Standard  $150\Omega$  Video Load with 0dB or  $+6\text{dB}$  Gain
- ◆ Dual-Supply Operation  
MAX7450 ( $\pm 5\text{V}$ )  
MAX7451 ( $\pm 3.3\text{V}$ )
- ◆ Tiny 8-Pin SO Package

### Ordering Information

PART	TEMP RANGE	PIN-PACKAGE	SUPPLY VOLTAGE (V)
MAX7450ESA	$-40^\circ\text{C}$ to $+85^\circ\text{C}$	8 SO-EP**	$\pm 5$
MAX7451ESA*	$-40^\circ\text{C}$ to $+85^\circ\text{C}$	8 SO-EP**	$\pm 3.3$
MAX7452ESA	$-40^\circ\text{C}$ to $+85^\circ\text{C}$	8 SO-EP**	+5

\*Future product—contact factory for availability.

\*\*EP = Exposed pad.

### Functional Diagram

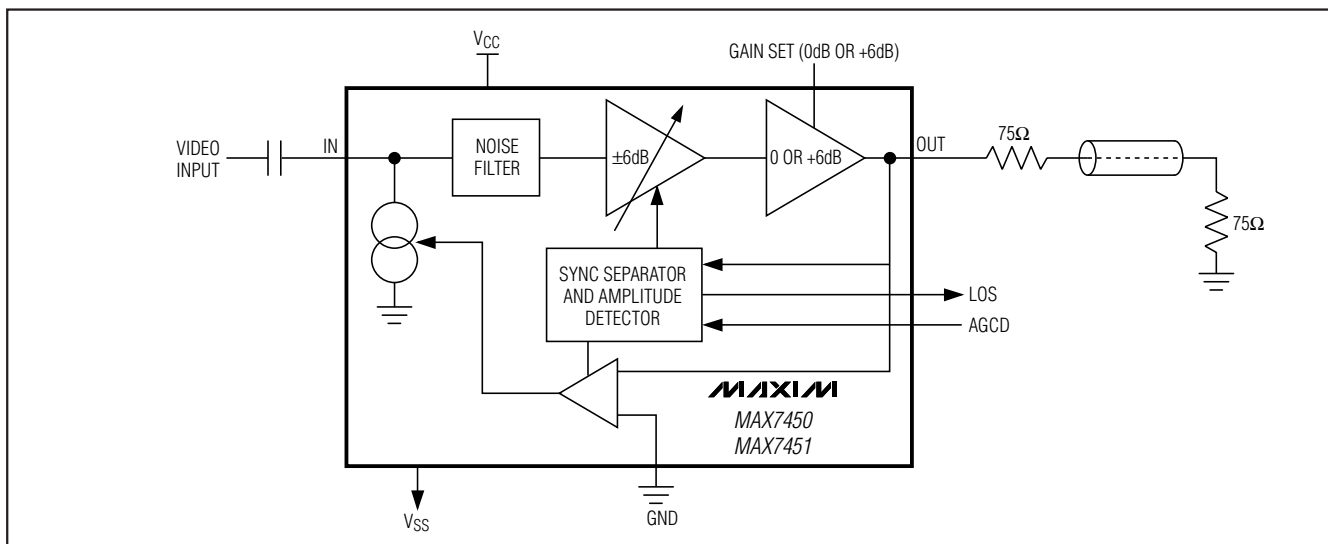

# Video-Signal Conditioners with AGC and Back-Porch Clamp

## ABSOLUTE MAXIMUM RATINGS

V <sub>CC</sub> to GND		All Other Pins
MAX7450/MAX7452.....	+6V	MAX7450/MAX7451.....
MAX7451.....	+4V	MAX7452.....
V <sub>SS</sub> to GND		Maximum Current into Any Pin.....
MAX7450.....	-6V	.....±50mA
MAX7451.....	-4V	Continuous Power Dissipation (T <sub>A</sub> = +70°C)
OUT		8-Pin SO (derate 18.9mW/°C above +70°C).....
MAX7450/MAX7451.....	-2.5V to +3.5V	Operating Temperature Range.....
MAX7452.....	-0.3V to (V <sub>CC</sub> + 0.3V)	Storage Temperature Range.....
GSET, AGCD, LOS.....	-0.3V to (V <sub>CC</sub> + 0.3V)	Junction Temperature.....
		Lead temperature (soldering, 10s).....

Stresses beyond those listed under "Absolute Maximum Ratings" may cause permanent damage to the device. These are stress ratings only, and functional operation of the device at these or any other conditions beyond those indicated in the operational sections of the specifications is not implied. Exposure to absolute maximum rating conditions for extended periods may affect device reliability.

## ELECTRICAL CHARACTERISTICS

(V<sub>SUPPLY</sub> = ±5V ±5% (MAX7450), V<sub>SUPPLY</sub> = ±3.3V ±5% (MAX7451), V<sub>SUPPLY</sub> = +5V ±5% (MAX7452), R<sub>L</sub> = 150Ω to GND, C<sub>L</sub> = 0 to 20pF, GSET = 1, AGCD = 1, T<sub>A</sub> = T<sub>MIN</sub> to T<sub>MAX</sub>, unless otherwise noted. Typical values are at T<sub>A</sub> = +25°C.)

PARAMETER	SYMBOL	CONDITIONS	MIN	TYP	MAX	UNITS	
Clamp Accuracy		MAX7450/MAX7451, relative to GND			±50	mV	
		MAX7452, relative V <sub>BPLVL</sub> = 1.5V			±50		
Back-Porch Level Input Range	V <sub>BPLVL</sub>	MAX7452	GSET = 0	1.0	3.0	V	
			GSET = 1	1.2	2.4		
Clamp Response Time	t <sub>CLAMP</sub>	Blanking level at the output to 1% of final value		70		Lines	
AGC Accuracy		AGCD = 0, V <sub>IN</sub> = 0.5V <sub>P-P</sub> to 2V <sub>P-P</sub>	GSET = 0, relative to V <sub>OUT</sub> = 1V <sub>P-P</sub>		±10	%	
			GSET = 1, relative to V <sub>OUT</sub> = 2V <sub>P-P</sub>		±10		
AGC Input Range		AGCD = 0, relative to V <sub>IN</sub> = 1V <sub>P-P</sub>	-6.0		+6.0	dB	
Gain Flatness	G <sub>F</sub>	f = 5MHz relative to 100kHz	-0.3		+0.3	dB	
Noise-Filter Cutoff	F <sub>c</sub>			10		MHz	
Low-Frequency Gain		f = 100kHz	GSET = 0	0.95	1	1.05	V/V
			GSET = 1	1.85	2	2.05	
Group-Delay Deviation	Δt <sub>G</sub>	3.58/4.43MHz relative to 100kHz			15	ns	
Differential Gain	dG	Five-step modulated staircase (V <sub>IN</sub> = 1V <sub>P-P</sub> )		0.2	0.6	%	
Differential Phase	dθ	Five-step modulated staircase (V <sub>IN</sub> = 1V <sub>P-P</sub> )		0.2	0.6	Degrees	

# Video-Signal Conditioners with AGC and Back-Porch Clamp

MAX7450/MAX7451/MAX7452

## ELECTRICAL CHARACTERISTICS (continued)

(V<sub>SUPPLY</sub> = ±5V ±5% (MAX7450), V<sub>SUPPLY</sub> = ±3.3V ±5% (MAX7451), V<sub>SUPPLY</sub> = +5V ±5% (MAX7452), R<sub>L</sub> = 150Ω to GND, C<sub>L</sub> = 0 to 20pF, GSET = 1, AGCD = 1, T<sub>A</sub> = T<sub>MIN</sub> to T<sub>MAX</sub>, unless otherwise noted. Typical values are at T<sub>A</sub> = +25°C.)

PARAMETER	SYMBOL	CONDITIONS		MIN	TYP	MAX	UNITS
Signal-to-Noise Ratio	SNR	Output signal peak-to-peak to RMS noise (100Hz to 5MHz)	GSET = 0, V <sub>OUT</sub> = 1V <sub>P-P</sub>	68			dB
			GSET = 1, V <sub>OUT</sub> = 2V <sub>P-P</sub>	65			
Line Time Distortion	H <sub>DIST</sub>	18μs, 100 IRE bar				0.2	%
Field Time Distortion	V <sub>DIST</sub>	130 lines, 18μs, 100IRE bar				0.5	%
Input Leakage Current	I <sub>IN</sub>				1	5	μA
Output Dynamic Range		V <sub>IN</sub> = 1V <sub>P-P</sub> , dG / dP < 3% / degrees			2	2.4	V <sub>P-P</sub>
Power-Supply Rejection Ratio	PSRR	V <sub>CC</sub> + 100mV <sub>P-P</sub> , f = 3.5MHz	AGCD = 1		30		dB
			AGCD = 0 with maximum gain		20		
Supply Current		MAX7450				35	mA
		MAX7452				20	
Logic-High Input	V <sub>IH</sub>			0.7 x V <sub>CC</sub>			V
Logic-Low Input	V <sub>IL</sub>					0.3 x V <sub>CC</sub>	V
Logic-High Output	V <sub>OH</sub>	I <sub>SOURCE</sub> = 500μA		V <sub>CC</sub> - 0.5			V
Logic-Low Output	V <sub>OL</sub>	I <sub>SINK</sub> = 500μA				0.4	V
Input Current Logic-High	I <sub>IH</sub>	Logic input sink				10	μA
Input Current Logic-Low	I <sub>IL</sub>	Logic input source				10	μA

# Video-Signal Conditioners with AGC and Back-Porch Clamp

## Typical Operating Characteristics

$V_{SUPPLY} = \pm 5V \pm 5\%$  (MAX7450),  $V_{SUPPLY} = \pm 3.3V \pm 5\%$  (MAX7451),  $V_{SUPPLY} = +5V \pm 5\%$  (MAX7452),  $R_L = 150\Omega$  to GND,  $C_L = 0$  to 20pF, GSET = 1, AGCD = 1.  $T_A = +25^\circ C$ , unless otherwise noted.

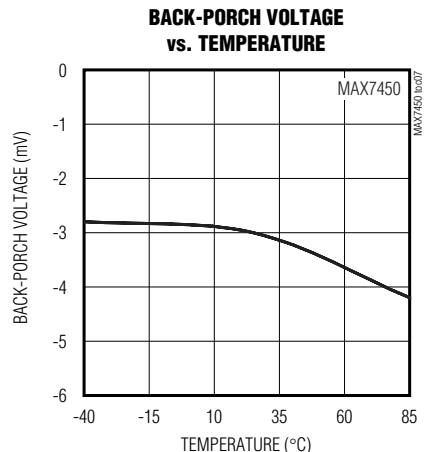
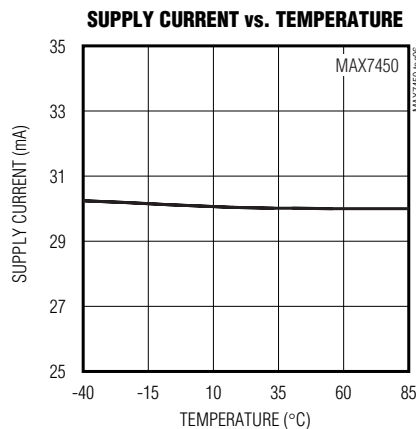
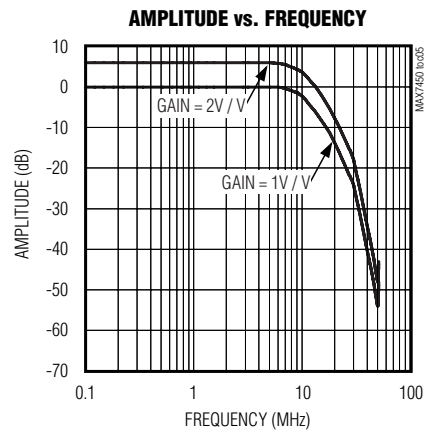
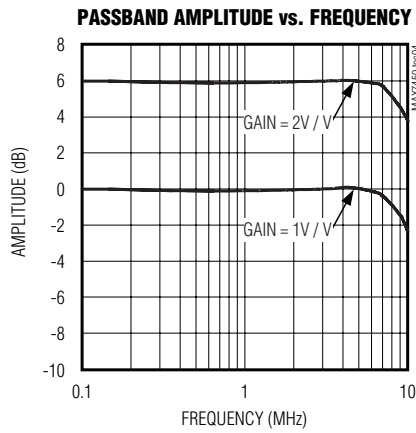
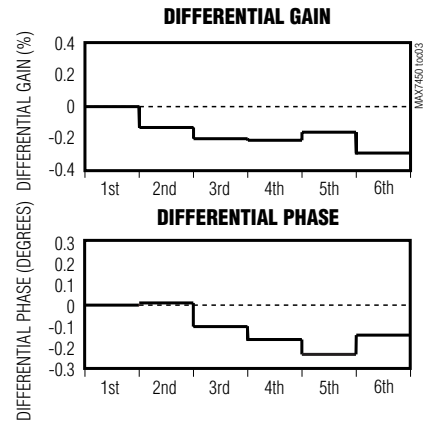
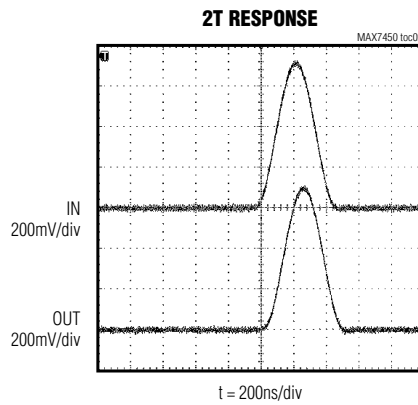
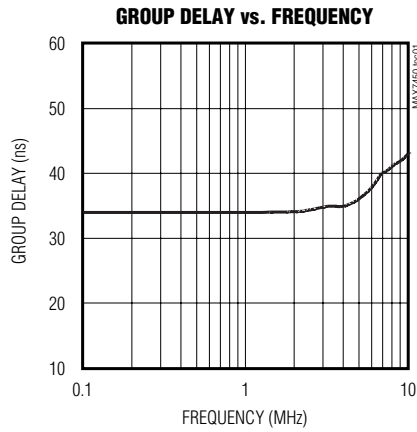

# Video-Signal Conditioners with AGC and Back-Porch Clamp

## Typical Operating Characteristics (continued)

$V_{SUPPLY} = \pm 5V \pm 5\%$  (MAX7450),  $V_{SUPPLY} = \pm 3.3V \pm 5\%$  (MAX7451),  $V_{SUPPLY} = +5V \pm 5\%$  (MAX7452),  $R_L = 150\Omega$  to GND,  $C_L = 0$  to 20pF, GSET = 1, AGCD = 1.  $T_A = +25^\circ C$ , unless otherwise noted.

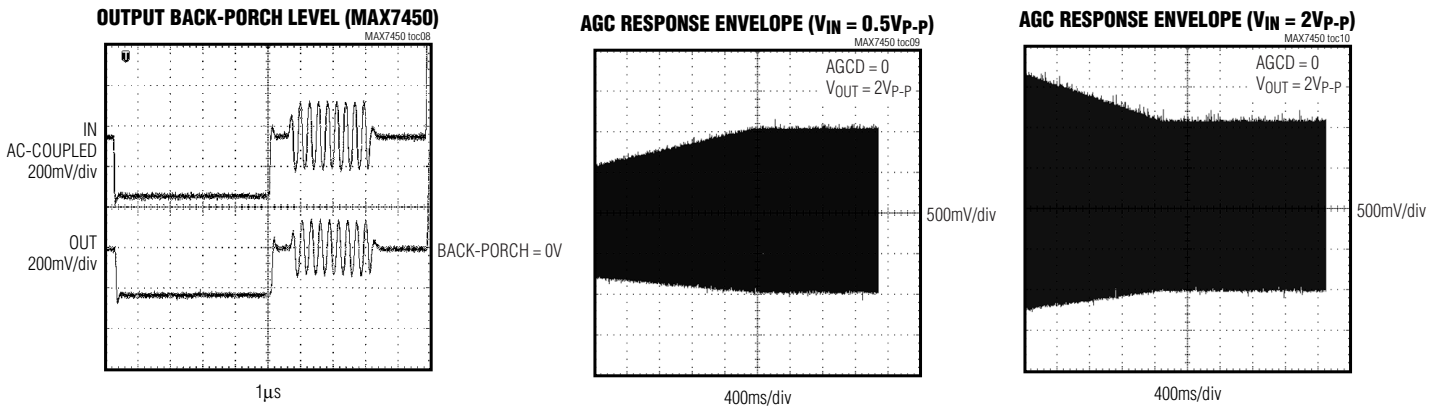

## Pin Description

PIN		NAME	FUNCTION
MAX7450/ MAX7451	MAX7452		
1	1	$V_{CC}$	Positive Power Supply. Connect +5V to $V_{CC}$ for the MAX7450/MAX7452. Connect +3.3V to $V_{CC}$ for the MAX7451. Bypass to GND with 1μF and 0.1μF capacitors as close to the pin as possible.
2	2	IN	Video Input. AC-couple video signal through a 0.1μF capacitor.
3	3	GND	Ground
4	—	$V_{SS}$	Negative Power Supply. Connect -5V to $V_{SS}$ for the MAX7450. Connect -3.3V to $V_{SS}$ for the MAX7451. Bypass to GND with 1μF and 0.1μF capacitors as close to the pin as possible.
—	4	BPLVL	Back-Porch Level Input. When gain = 2V/V (GSET = 1), output back-porch level is equal to BPLVL input. When gain = 1V/V (GSET = 0), output back-porch level is equal to $V_{BPLVL}/1.5$ .
5	5	AGCD	Automatic Gain-Control Disable Input. Disable AGC by driving AGCD to $V_{CC}$ . Enable AGC by driving AGCD to GND.
6	6	OUT	Video Output
7	7	GSET	Gain-Setting Input. Drive GSET high to set buffer gain to +6dB. Drive GSET low to set buffer gain to 0dB.
8	8	LOS	Loss-of-Sync Logic Output. LOS is high when video sync is lost for more than 15 horizontal lines. LOS goes low when video sync is present.
—	—	EP	Exposed Pad. Connect to $V_{SS}$ (MAX7450/MAX7451). Connect to GND (MAX7452).

MAX7450/MAX7451/MAX7452

# Video-Signal Conditioners with AGC and Back-Porch Clamp

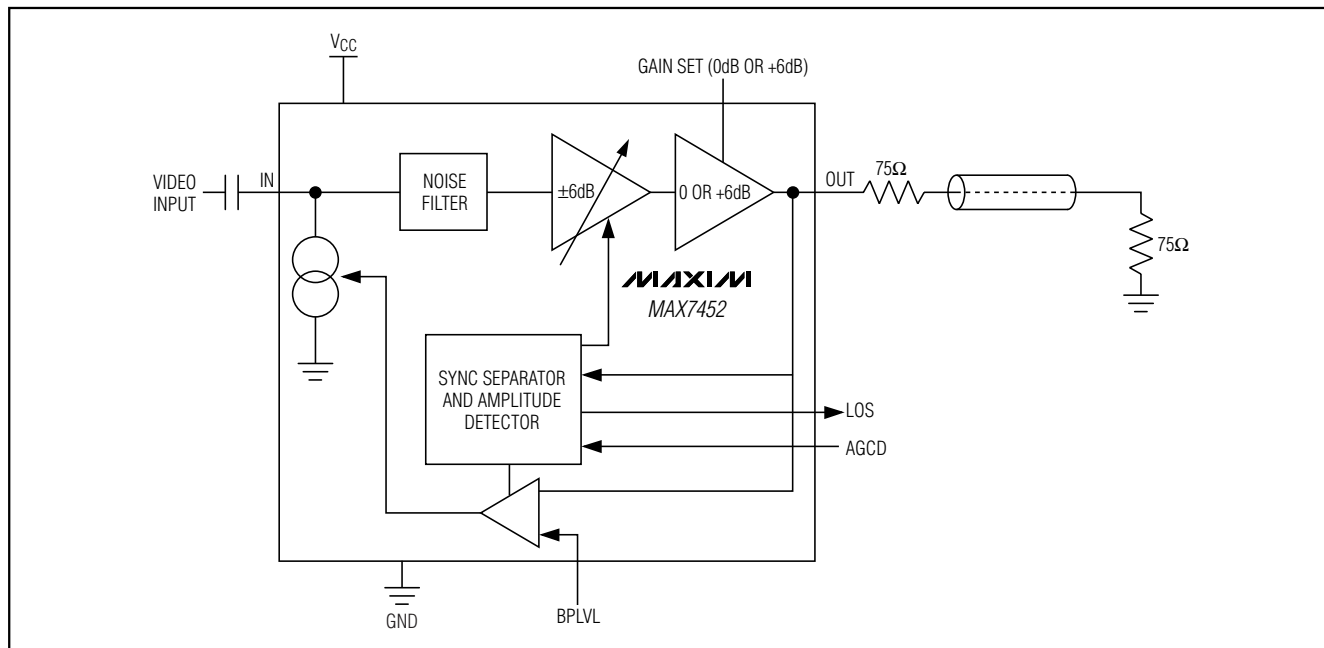

Figure 1. MAX7452 Functional Diagram

## Detailed Description

As shown in Figure 1, the devices include a 2nd-order lowpass filter intended to reject out-of-band noise. The MAX7450/MAX7451 clamp the back-porch voltage to ground, and the MAX7452 clamps to a user-supplied reference voltage. These devices also include an automatic gain control (AGC), which automatically adjusts the gain to ensure the sync amplitude is normalized to a standard video level; an AGC disable function; and an output driver that drives a standard video load ( $150\Omega$ ) with a full  $2V_{P-P}$  video signal ( $GSET = 1$ ) or  $1V_{P-P}$  video signal ( $GSET = 0$ ).

The clamp and the AGC work concurrently. Interaction between the two different control loops is eliminated by the large difference in time constants. The time constant of the clamp settles within 100 lines, while the AGC loop is digitally stepped so that it settles between 1000–64,000 lines.

The AGC control works independently of the gain setting of the output buffer. The overall gain is the multiplication of the AGC gain and the output buffer gain. The maximum overall gain is +12dB and the minimum gain is -6dB.

## Back-Porch Clamp

The MAX7450/MAX7451/MAX7452 feature a back-porch clamp to set the output blanking level. The devices sense the voltage during back porch and feed back into a control system. The control system provides the appropriate DC-level shift to clamp the output to ground (MAX7450/MAX7451) or to a voltage set by  $V_{BPLVL}$  (MAX7452). This restores the DC level for further video processing such as on-screen display (OSD) insertion and analog-to-digital conversion. The back-porch clamp to ground also eliminates the need for large output-coupling capacitors that can introduce unwanted line-time distortion (tilt) and cost. This can also reduce board space. The feedback network and the on-chip capacitors introduce a finite settling time after power-up or after any dramatic shift in input voltage (see the *Electrical Characteristics* section).

## Back-Porch Level Input (MAX7452)

The MAX7452 features an adjustable back-porch level at the output as shown in Figure 1.  $V_{BPLVL}$  sets the back-porch clamp level. The back-porch clamp-output level is defined by the following equations.

$$GSET = 1 \text{ (Gain} = 2V/V\text{), } V_{BACKPORCHLEVEL} = V_{BPLVL}$$

$$GSET = 0 \text{ (Gain} = 1V/V\text{), } V_{BACKPORCHLEVEL} = V_{BPLVL} / 1.5$$

# Video-Signal Conditioners with AGC and Back-Porch Clamp

**Table 1. Gain-Control Settings**

AGCD	GSET	OUTPUT
0	0	1V <sub>P-P</sub> fixed
0	1	2V <sub>P-P</sub> fixed
1	0	V <sub>OUT</sub> = V <sub>IN</sub>
1	1	V <sub>OUT</sub> = 2V <sub>IN</sub>

### Automatic Gain Control (AGC)

The MAX7450/MAX7451/MAX7452 have an integrated automatic gain-control circuit to ensure the sync amplitude is normalized to the standard level, thus normalizing the overall amplitude to a standard level. The accuracy of the normalized amplitude assumes the ratio of active video to sync amplitude is correct in the input video signal. The gain is adjusted automatically by detecting and comparing the amplitude of the sync pulse to a fixed internal reference. If the sync amplitude is less than this value, the overall gain is increased until the sync amplitude equals this reference. However, if the sync amplitude is high, the overall gain is reduced accordingly. Disable the AGC loop by driving AGCD high.

When designing the overall system, it is important to note that the AGC can correct for termination problems. First, disable the AGC and verify that the terminations are correct, and then enable the AGC for proper operation.

### Output Buffer

The output buffer of the MAX7450/MAX7451/MAX7452 is designed to drive either standard video loads or high-impedance loads, independent of the buffer gain. Logic levels on GSET and AGCD set the gain of the MAX7450/MAX7451/MAX7452. Table 1 shows the different gain-setting configurations.

### Noise Filter

The MAX7450/MAX7451/MAX7452 feature a simple 2nd-order lowpass filter to reject out-of-band noise that may be introduced by the long cable connection between the cameras and the switching matrix.

### LOS Detector

The LOS detector of the MAX7450/MAX7451/MAX7452 outputs a logic high when the sync is not present (loss of video signal) for at least 15 horizontal lines on the input. This can be used to indicate a fault condition of the camera or cable.

## Applications Information

### Connecting the MAX7450/MAX7451 to a Crosspoint Switch

The MAX7450/MAX7451/MAX7452 are designed to directly interface to a video crosspoint switching device such as those used in security systems (see Figure 2). The MAX7450/MAX7451 clamp the video output to GND, making the devices an ideal interface to the MAX4358 crosspoint switches and the MAX4455 OSD. The MAX7450/MAX7451 and the MAX4455 have their outputs referenced to ground, ensuring the amplitudes and the brightness of the OSD relative to the video signal are accurate.

### Interfacing the MAX7452 to an ADC

The MAX7452 can be directly connected to an ADC or video decoder as shown in Figure 3. The video output of the MAX7452 is DC-coupled to a single-ended video input on the ADC. The voltage on the BPLVL pin sets the black level of the video signal at the output of the MAX7452. Use a stable voltage reference for the BPLVL voltage, ideally the same reference that is used

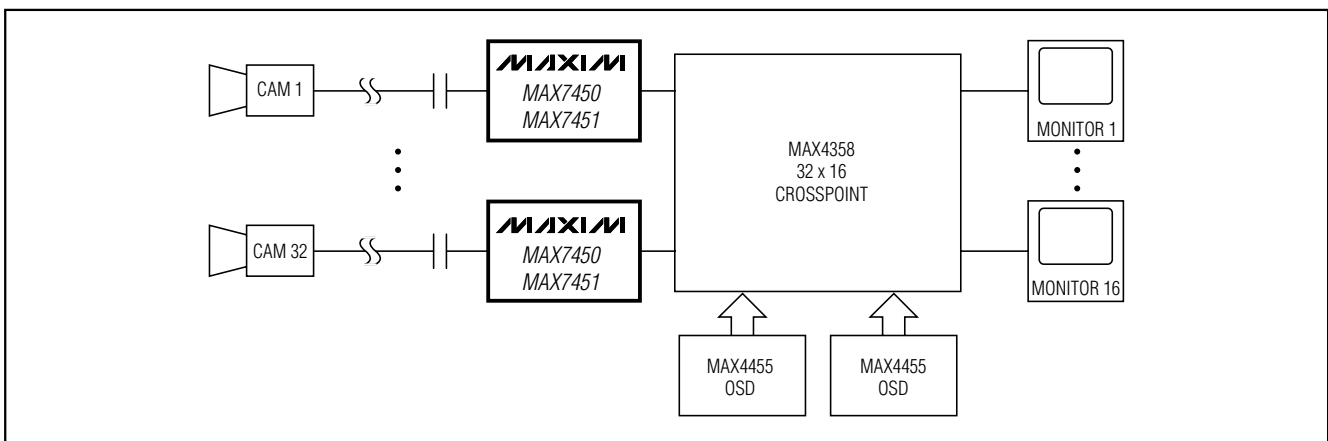

Figure 2. MAX7450/MAX7451 in a 32 x 16 Crosspoint Application

# Video-Signal Conditioners with AGC and Back-Porch Clamp

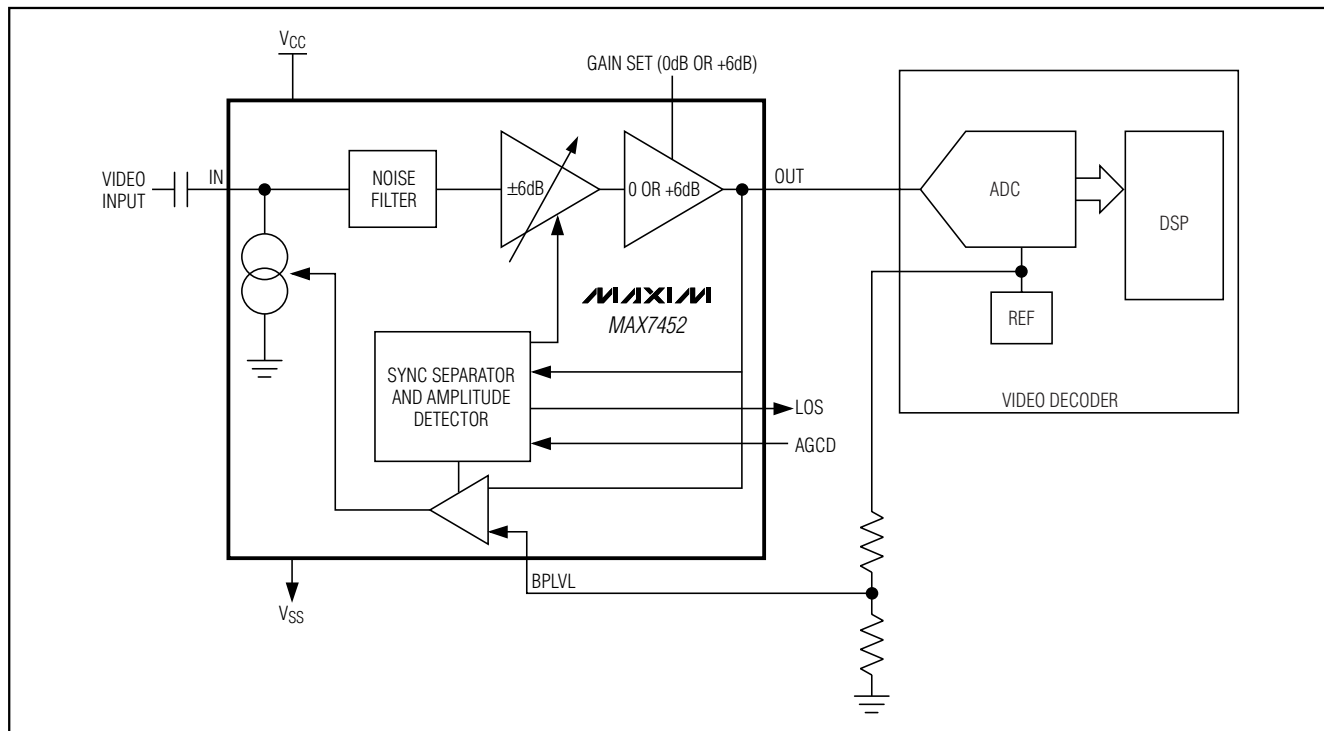

Figure 3. MAX7452 Interfaced to a Video Decoder

for the analog-to-digital conversion. This voltage must be scaled by a ratio of two resistors to set the black level of the video signal to the appropriate level (to match the input range of the converter).

If the ADC or video decoder has a built-in clamp circuit, the output of the MAX7452 must be AC-coupled into the ADC with the capacitor value recommended for the converter. In this situation, set the BPLVL on the MAX7452 to the midpoint of the specified range for optimum performance. In addition, the stability of this voltage is not critical, provided that it stays within the specified range.

### Power-Supply Bypassing and Layout

Bypass all supply pins to GND with 0.1 $\mu$ F and 1 $\mu$ F capacitors. These capacitors filter higher frequencies in the MHz range. Place all external components as close to the devices as possible. Connect EP to V<sub>SS</sub> for the MAX7450/MAX7451. Connect EP to GND for the MAX7452. Placing the IC onto a copper area the size of the pad is recommended for proper power dissipation. Refer to the *MAX7450 Evaluation Kit* for a proven PC-board layout example.

### Chip Information

TRANSISTOR COUNT: 6316  
PROCESS: BiCMOS

### Pin Configuration

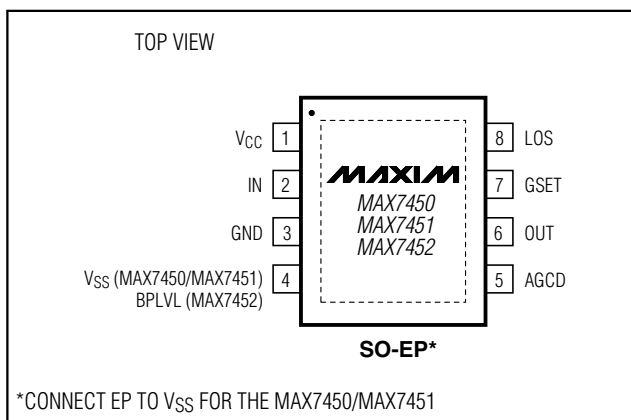



# Video-Signal Conditioners with AGC and Back-Porch Clamp

## Package Information

(The package drawing(s) in this data sheet may not reflect the most current specifications. For the latest package outline information, go to [www.maxim-ic.com/packages](http://www.maxim-ic.com/packages).)

MAX7450/MAX7451/MAX7452

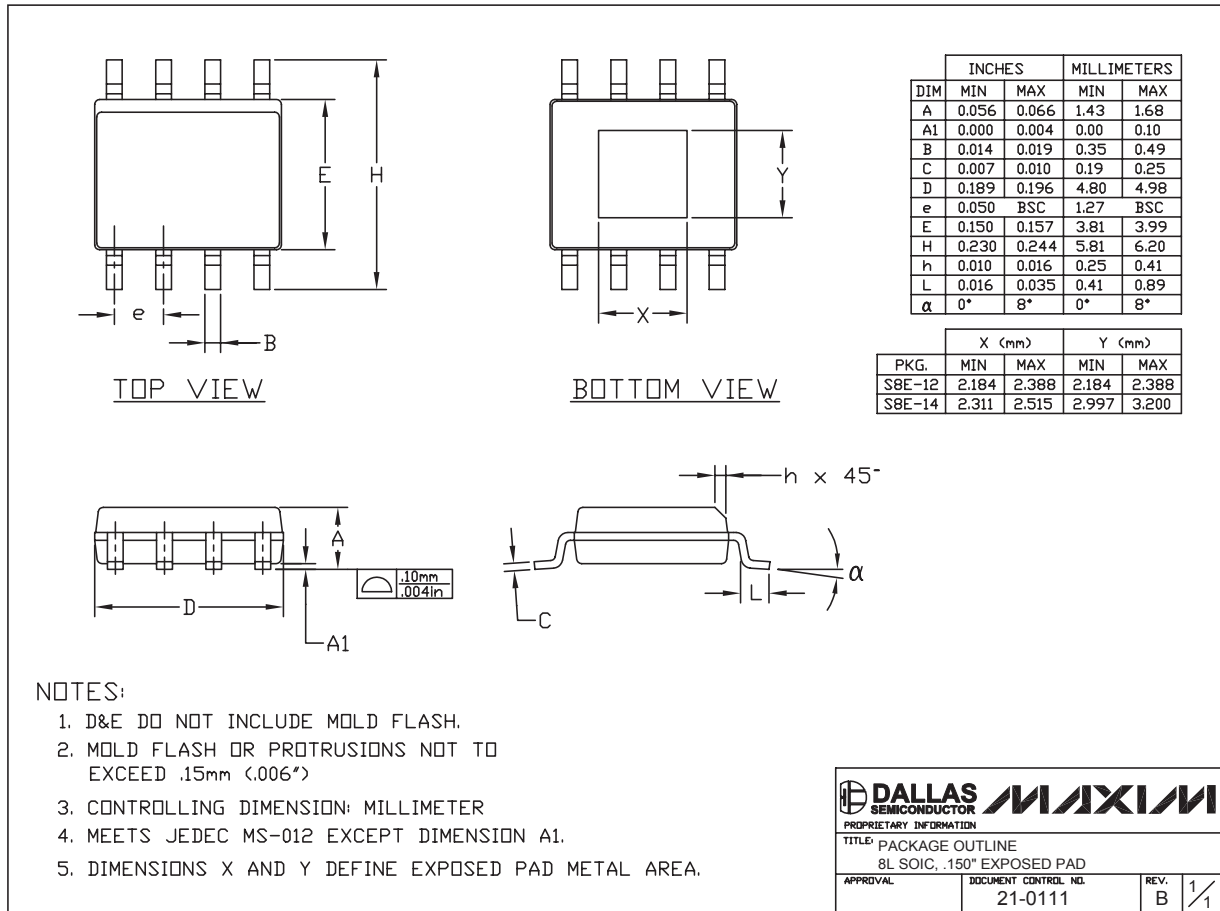

Maxim cannot assume responsibility for use of any circuitry other than circuitry entirely embodied in a Maxim product. No circuit patent licenses are implied. Maxim reserves the right to change the circuitry and specifications without notice at any time.

Maxim Integrated Products, 120 San Gabriel Drive, Sunnyvale, CA 94086 408-737-7600 9